

Asterion

Sorensen

Asterion Half Rack Series

High Performance Programmable DC Power Supply

1.7 kW

40 V to 600 V

2.8 A to 42 A

Advanced Features

- High power density up to 1.7 kW in a 1U half rack chassis
- Fixed or autoranging output models
- Intuitive touch panel control
- Multi-language display for global operation
- Auto paralleling for higher power
- Active power factor correction (PFC)
- Standard LXI LAN, USB, and RS232 interfaces
- Optional EtherCAT and GPIB interface
- Full remote control via Virtual Panels™



Performance. Reliance. Brilliance.

The Sorensen™ Asterion® DC Half Rack Series is the newest addition to the Asterion platform of power testing solutions. The new DC series features two types of product lines: fixed range and autoranging. The fixed range supplies are economical, traditional, rectangular wave output power supplies with all the enhanced operation advantages standard with the Asterion platform. The autoranging supplies feature expanded current and voltage range at the full output power level, enabling the ability to satisfy a wider testing need without requiring the purchase of additional models.

Maximize rack space utilization with leading DC power density in a ½ rack 1U size.

Autoranging models satisfy a wider testing need in a single power supply.

Quickly and expertly control the DC supply with intuitive touchscreen.

Control via Front Panel Touchscreen & Encoder Knob or available digital control interfaces

The Asterion DC Half Rack source is Digital Signal Processor (DSP) controlled and can be operated from the intuitive, easy-to-use front panel touchscreen or the Ethernet LXI, USB, RS232 standard control interfaces, as well as through the optional GPIB and EtherCAT control interface. Supply is provided with external user I/O for Remote Inhibit, Remote ON/OFF, Status and Trigger functions. In addition to the I/O signals power source also provides with Auxiliary 5 V and 15 V outputs that could be used as control power. Source also provides control interface connectors for the parallel operation of the power supplies.

The touchscreen function group icons include a Dashboard, Output Programming Parameters, Measurements, Sequencing, Configuration, Control Interfaces, Applications and System Settings. Function selection and parameter entry can be achieved either by direct selection from the touchscreen or by using the encoder selector

button. The control resolution is adjusted by a dynamic rate change algorithm that combines the benefits of precise control over small parameter changes with quick sweeps through the entire range.

Applications

The Asterion DC Half Rack Series is designed for testing today's complex electronics, including telecommunications and commercial electronics requiring low profile, light weight power supplies with high power density. Other applications include: Military and aerospace electronics test

- ATE applications
- Military and aerospace electronics test
- DC power simulation
- Commercial manufacturing and process control
- Research and development
- Automotive component and battery testing

Auto Ranging Model Output Characteristic

The Asterion DC autoranging models have an output characteristic where the full rated output power is available at voltage and current ranges greater than the conventional rectangular output characteristic of fixed range power supplies. The output current versus output voltage follows a constant-power curve to provide users a wider current and voltage operating range in a single power supply.

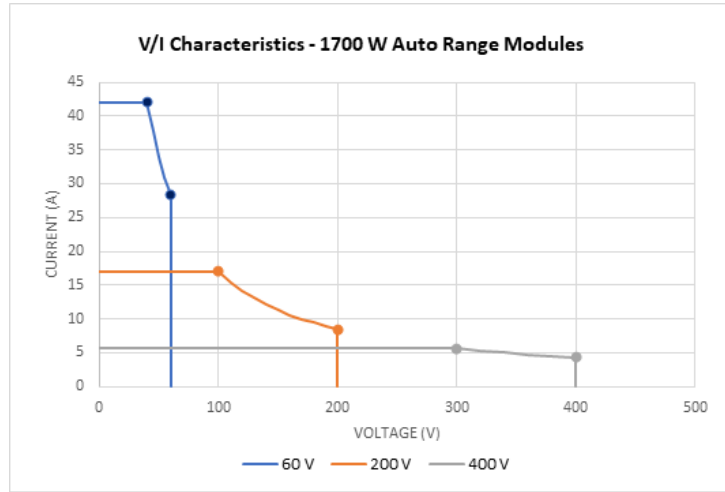
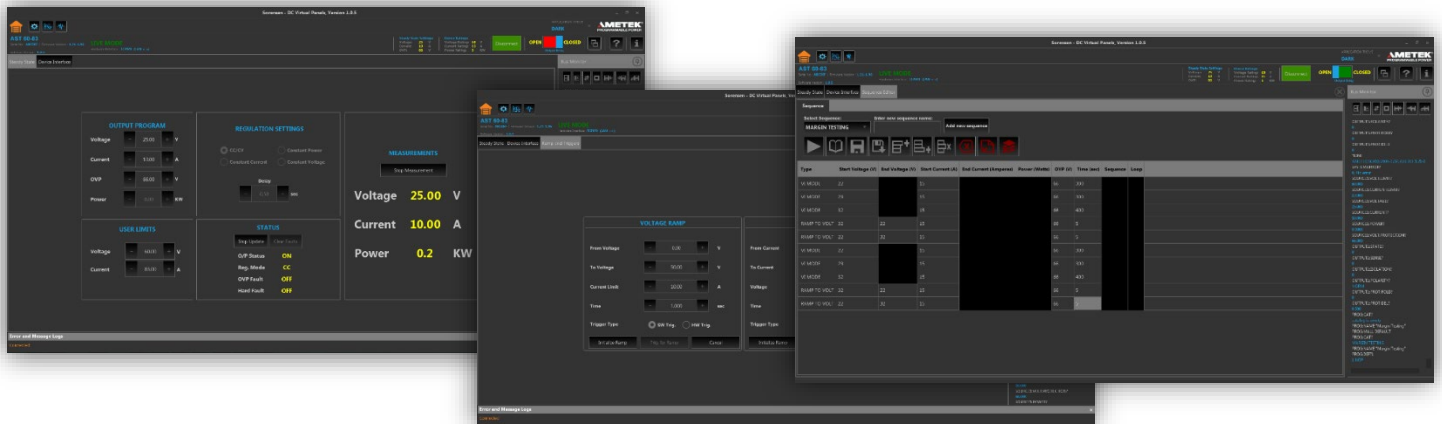

Figure 1 – Auto Range Models Voltage vs Current Output Characteristics

Asterion DC Virtual Panels (Graphical User Interface)

Virtual Panels allow remote control of the Asterion DC power supply as well as programming communication and monitoring of the instrument without the front panel display. You can perform all operations via the remote Virtual Panels control as you could working directly with the unit’s front panel.



Virtual Panels “main status,” “sequencing” and “output ramp” screens are shown.

Specifications

Asterion Half Rack Output Specifications – 1.7 kW Fixed Range Models										
MODEL		ASH 40-42	ASH 60-28	ASH 80-22	ASH 100-17	ASH 150-12	ASH 200-8.5	ASH 300-5.6	ASH 400-4.3	ASH 600-2.8
Rated Output Voltage	V	40	60	80	100	150	200	300	400	600
Rated Output Current	A	42	28	22	17	12	8.5	5.6	4.3	2.8
Rated Output Power	W	1700	1700	1700	1700	1700	1700	1700	1700	1700
Line Regulation	V	+/- 0.01% of rated voltage								
	A	+/- 0.05% of rated current								
Load Regulation	V	+/- 0.02% of rated voltage								
	A	+/- 0.15% of rated current								
Ripple RMS (20Hz-300kHz) c.v	mV	7	7	12	12	20	20	40	40	60
Output noise p-p (20Hz-20MHz) c.v	mV	60	60	75	75	75	100	300	300	300
Remote sense compensation		5% maximum of rated output voltage								
Temperature drift	PPM/C	100								
Stability		0.05% of output rating								

Asterion Half Rack Output Specifications – 1.7 kW Auto Range Models				
MODEL		ASH 60-42AR	ASH 200-17AR	ASH 400-6AR
Rated Output Voltage	V	60	200	400
Rated Output Current	A	42	17	6
Rated Output Power	W	1700	1700	1700
Line Regulation	V	+/- 0.01% of rated voltage		
	A	+/- 0.05% of rated current		
Load Regulation	V	+/- 0.02% of rated voltage		
	A	+/- 0.15% of rated current		
Ripple RMS (20Hz-300kHz) c.v	mV	12	20	40
Output noise p-p (20Hz-20MHz) c.v	mV	75	100	300
Remote sense compensation		5% maximum of rated output voltage		
Temperature drift	PPM/C	100		
Stability		0.05% of output rating		

Programming & Readback (Front Panel or Remote Digital Interface)	
Voltage Output programming accuracy	+/- 0.1% of rated output voltage
Current Output programming accuracy	+/- 0.2% of rated output current
Power Output programming accuracy	+/- 0.3% of rated output power
Overvoltage programming accuracy	+/- 1%, maximum, of rated output voltage
Voltage Output programming resolution	0.012% of full scale
Current Output programming resolution	0.012% of full scale
Power Output programming resolution	0.012% of full scale
Overvoltage programming resolution	0.1% of full scale
Voltage Output Readback accuracy	+/- 0.1% of rated output voltage
Current Output Readback accuracy	+/- 0.2% of rated output current
Power Output Readback accuracy	+/- 0.3% of rated output power
Voltage Output readback resolution	0.012% of full scale
Current Output readback resolution	0.012% of full scale
Power Output readback resolution	0.012% of full scale
Overvoltage Response time	20 ms

1.7 kW Output Transient Specifications									
	Rated Voltage (V)								
	40 V	60 V	80 V	100 V	150 V	200 V	300 V	400 V	600 V
Voltage Rise Time¹ (ms), Full load	20	20	25	25	50	75	100	100	150
Voltage Fall Time² (ms), Full load	50	50	60	60	120	150	200	200	200
Voltage Fall Time³ (ms), No load	1200	1500	2600	2600	2900	3500	4600	4600	4800
Transient response⁴ (ms)	1	1	1	2	2	2	2	2	2

¹ Maximum time, from 0-100% of programming change from zero to rated output voltage with rated resistive load. Current rise time is same as the voltage rise time

² Maximum time, from 100%-0 of programming change from rated output voltage to zero with rated resistive load. Current fall time is same as the voltage fall time

³ Maximum time, from 100%-0 of programming change from rated output voltage to zero with No load

⁴ Typical time to recover within 0.5% of rated output voltage for load step change 10-90% of rated output current

1.7 kW Autoranging Output Transient Specifications			
	Rated Voltage (V)		
	60 V	200 V	400 V
Voltage Rise Time¹ (ms), Full load	20	75	100
Voltage Fall Time² (ms), Full load	50	150	200
Voltage Fall Time³ (ms), No load	1500	3500	4600
Transient response⁴ (ms)	1	2	2

¹⁾ Maximum time, from 0-100% of programming change from zero to rated output voltage with rated resistive load.
Current rise time is same as the voltage rise time

²⁾ Maximum time, from 100%-0 of programming change from rated output voltage to zero with rated resistive load.
Current fall time is same as the voltage fall time

³⁾ Maximum time, from 100%-0 of programming change from rated output voltage to zero with No load

⁴⁾ Typical time to recover within 0.5% of rated output voltage for load step change 10-90% of rated output current

Remote Control Digital Interfaces	
LAN	Ethernet 10BASE-T and 100BASE-T over twisted-pair cables compliant with IEEE 802.3; Connector: 8P8C modular jack.
RS-232	Serial interface compliant to RS-232C; Protocol: data bits, 7 with parity and 8 without parity; stop bits, 2; baud rate, 9600 to 115200; handshake, CTS and RTS; Connector: Subminiature-D, 9-contact receptacle.
USB	Serial interface compliant to USB 2.0; Connector: Type-B receptacle.
ECAT-3 (Option)	EtherCAT (Ethernet for Control Automation Technology) is an Ethernet-based fieldbus system. The protocol is standardized in IEC 61158 and is suitable for both hard and soft real-time computing requirements in automation technology.
IEEE-488 (Option)	Parallel interface complies with IEEE-488.1, IEEE-488.2, and the SCPI command specification; command execution response time, 10 ms, typical; connector: IEEE-488.1 compliant.

Unit Protection	
Output Overvoltage Protection (OVP)	Programmable to 110% of full-scale output voltage, exceeding OVP threshold results in shutdown of output.
Output Current Limit Protection	User-selectable fold back mode CV/CC/CP or CV or CC or CP modes.
	In CV/CC/CP mode, output current or power is regulated to setpoint on reaching limit.
	In CV mode, on reaching current or power limits results in shutdown of output.
	In CC mode, on reaching voltage or power limits results in shutdown of output.
	In CP mode, on reaching voltage or current limits results in shutdown of output.
	In CV or CC or CP mode, shutdown delay on reaching the limit is programmable from 100 ms to 5 s.
AC Input Overcurrent Protection	Internal fuses in each phase for fault isolation; not user replaceable.
AC Input Undervoltage Protection	Automatic shutdown for insufficient AC input voltage.
AC Input Transient Protection	Protection to withstand EN61326-1, Class-A surge levels.
Overtemperature Protection (OTP)	Internal temperature monitors cause shutdown of output if temperature thresholds are exceeded.

AC Input Specifications	
Input Voltage Operating Nominal range	Input Type: 1 Phase, 2 wire + Gnd Nominal Rating Range for 1 phase, 2 wire+ Gnd Low Line range:100 –132 VAC ⁽¹⁾ , 1 Phase, Line-Neutral. Nominal Rating Range for 1 phase, 2 wire+ Gnd High Line range: 200–240 VAC, 1 Phase, Line-Neutral.
Input Voltage, Operating range	1 phase, 2 wire + Gnd, Low line , Operating Range 90-145 VAC Line-Neutral. 1 phase, 2 wire + Gnd, High line , Operating Range 180-264 VAC Line-Neutral.
Input Current, Maximum RMS	1 phase, 2 wire + Gnd, Low line : 24 A at 90 VAC Line-Neutral. 1 phase, 2 wire + Gnd, High line : 11.5 A at 180 VAC Line-Neutral.
Input Frequency, Nominal Rating	50 Hz, 60 Hz ⁽⁶⁾
Input Frequency Range	47 Hz- 63 Hz ⁽⁶⁾
Efficiency	1 phase, 2 wire + Gnd, Low line : 80% ⁽²⁾ 1 phase, 2 wire + Gnd, High line : 85% ⁽³⁾
Power Factor⁽⁵⁾, typical	1-Ph: 0.98; active PFC
Hold-Up Time⁽⁵⁾, typical	≥10 ms
Inrush Current, typical⁽⁴⁾	1 phase, 2 wire + Gnd, Low line : 16 A Peak @ 132 VAC L-N 1 phase, 2 wire + Gnd, High line : 34 A Peak @ 264 VAC L-N
Isolation Voltage	1500 VAC Input to Ground, 3000 VAC Input to Hazardous Secondary, 3000 VAC Input to Isolated SELV barriers

⁽¹⁾ Ensure the inlet wiring is capable of handling current up to 24 A on using Low line input and 12 A for the high line input to load up to 1700 W.

⁽²⁾ Typical value at full load 1700 W output and nominal AC input voltage of 110VAC L-N at 50/60 Hz input frequency.

⁽³⁾ Typical value at full load 1700 W output and nominal AC input voltage of 220VAC L-N at 50/60 Hz input frequency.

⁽⁴⁾ Not including EMI filter inrush less than 200us.

⁽⁵⁾ Measured at full load at rated nominal AC input voltage of 110 VAC/ 220 VAC L-N for single phase input.

⁽⁶⁾ Contact to factory for high frequency operation for more details.

Output Power Derating Characteristics with AC Input Voltage		
Derating Characteristics	40°C	50°C
Total Output Power	1700 W	1500 W

Output power is derated with operating temperature irrespective of high line (180-264VAC) and low line (90-132VAC) input.

Mechanical Specifications	
Dimensions	H, 1.7" (43.5 mm); W (front panel), 8.43" (214 mm); D, 24.0" (610 mm); H, 1.7" (43.5 mm); W (chassis), 8.43" (214 mm); D, 23.0" (584 mm).
Unit Weight	14lbs, maximum
Shipping Weight	20lbs, maximum
Chassis Material	Steel with plastic front panel
Chassis Finish	Galvanized Zinc, G90
Installation	Protective covers are provided for AC input and DC output. Rackmount: per ANSI-EIA-310-D, with front panel mounting flanges and chassis provisions for mounting rack slides; slides option available.
Cooling	Force-air cooling; linear, variable fan speed control; air intake at front/sides and exhaust at rear.
Acoustic Noise	68 dBA, maximum; measured at 1 m with A-weighting;

Environmental Specifications	
Operating Temperature	0°C to 40°C (32° F to 104° F) (1700 watts output) 0°C to 50°C (32° F to 122° F) (1500 watts output)
Storage Temperature	-40°C to 85°C (-40°F to 185° F)
Altitude	3000 m (10,000 ft), output current derating 2%/100 m or ambient temperature 1°C/100 m above 2000 m
Operating Humidity	20-90 %, non-condensing
Relative Humidity	10-95 %, non-condensing
Vibration	MIL-PRF-28800F, Class 3; 5-500 Hz per Paragraph 4.5.5.3.1.
Shock	MIL-PRF-28800F, Class 3; 30G half-sine with 11ms duration per Paragraph 4.5.5.4.1.
Transportation Integrity	ISTA Test Procedure 1A
Operating Temperature	0°C to 40°C (32° F to 104° F) (1700 watts output) 0°C to 50°C (32° F to 122° F) (1500 watts output)

Regulatory Agency Compliance	
EMC	CE marked for EMC Directive 2014/30/EU per EN 61326-1:2013 Class A for Emissions and Industrial Immunity levels as required.
Safety	NRTL certified for US and Canada to CAN/CSAC22.2 No. 61010112, UL 61010-1 Third Edition. CE marked for LVD Directive 2014/35/EU to EN 61010-1 Third Edition as required.
CE Mark LVD Categories	Installation Overvoltage Category II, Pollution Degree 2, Indoor use only.
RoHS	CE marked for RoHS Directive 2011/65/EU per EN IEC 63000:2018 as required.

Chassis Dimension Drawings (1U)

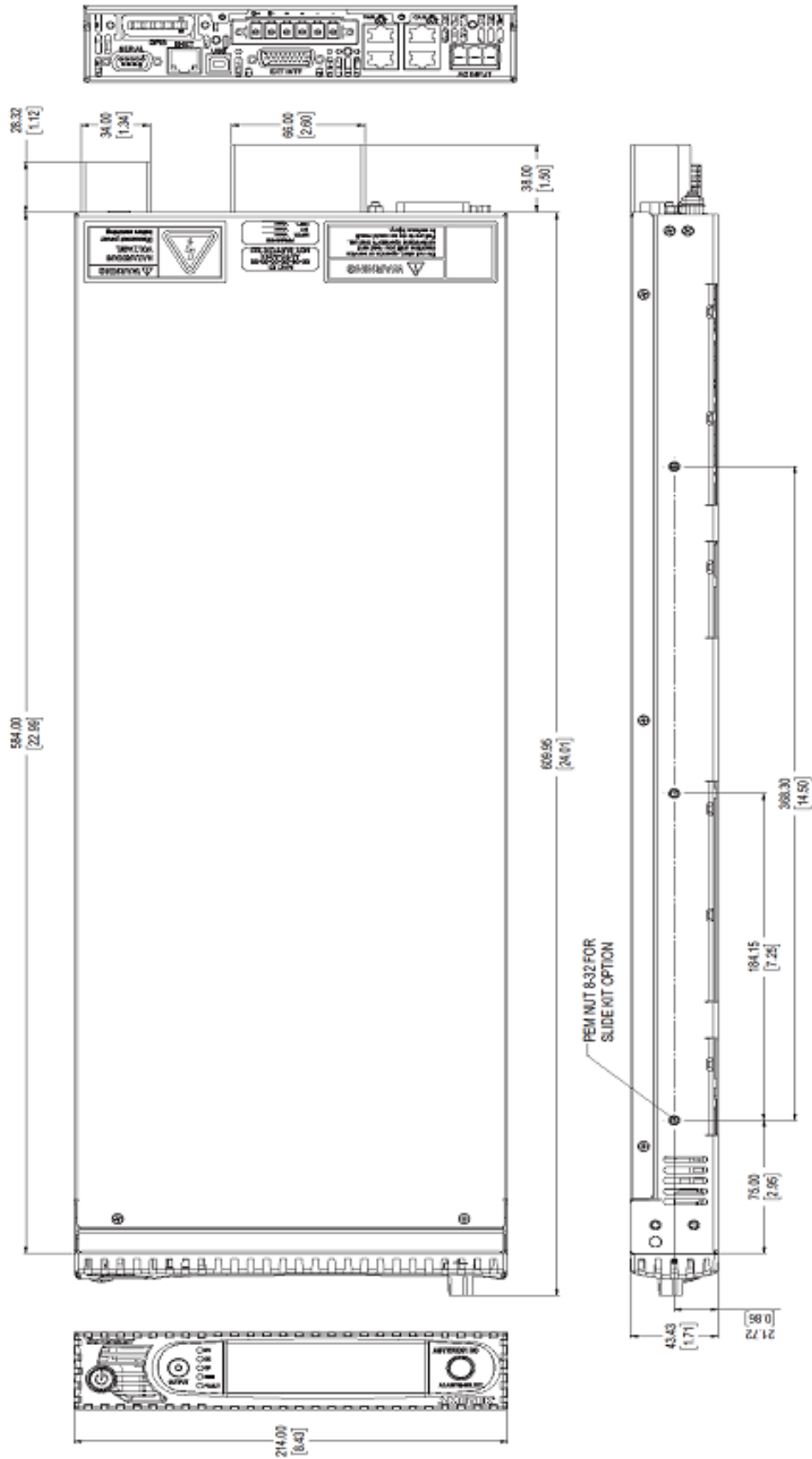

Options & Order Information

Option	Description
Interface Options	
Notes	
0	None
1	GPIB Interface
2	EtherCAT
Additional Options	
Notes	
1	Isolated Analog Interface
ACCESSORIES	
Notes	
5330809-01R	Rackmount Mounting kit for assembling two half rack units in the 19-inch Rack
5330809-02R	Rackmount Mounting kit for assembling one half rack unit and one dummy unit in the 19-inch Rack
ASH-Z540	ANSI Z540 Certified Calibration
ASH-17025	ISO 17025 Certified Calibration

Model Number Description:

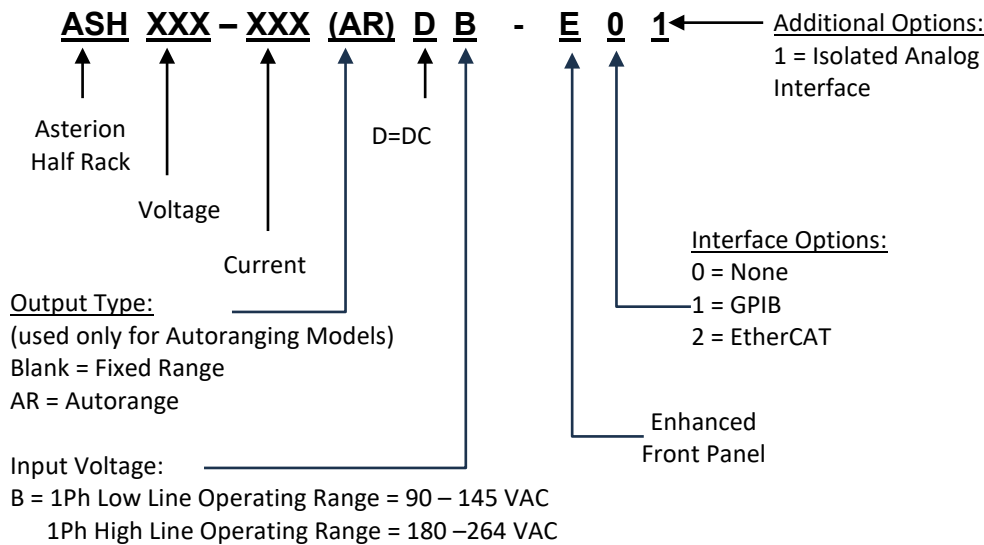

*** Note: See user manual for output power derating vs input voltage.**

Warranty Statement:

AMETEK Programmable Power Inc. warrants its products to be free from defects in material and workmanship. The warranty period is from the date of original shipment of the product to the original purchaser (see website for warranty periods by product). Asterion DC comes with a **five (5)** year warranty. Extended warranties available.

Note: All specifications subject to change without notice.

Thurlby Thandar Instrument Distribution
 Glebe Road, Huntingdon, PE29 7DR, UK
+44 (0)1480 412 451
sales@ttid.co.uk
www.ttid.co.uk

