

R&S® ZNLE

Vector Network Analyzer

Specifications



3 year warranty

CONTENTS

Definitions	3
Specifications.....	4
Measurement range	4
Measurement speed.....	5
Measurement accuracy	6
Effective system data.....	7
Factory-calibrated system data	7
Test port output	8
Test port input	9
Additional front panel connectors.....	10
Display	10
Rear panel connectors.....	10
Options	11
R&S®FPL1-B10	11
General data	12
Dimensions (in mm).....	13
Ordering information	14

Definitions

General

Product data applies under the following conditions:

- Three hours storage at ambient temperature followed by 30 minutes warm-up operation
- Specified environmental conditions met
- Recommended calibration interval adhered to
- All internal automatic adjustments performed, if applicable

Specifications with limits

Represent warranted product performance by means of a range of values for the specified parameter. These specifications are marked with limiting symbols such as $<$, \leq , $>$, \geq , \pm , or descriptions such as maximum, limit of, minimum. Compliance is ensured by testing or is derived from the design. Test limits are narrowed by guard bands to take into account measurement uncertainties, drift and aging, if applicable.

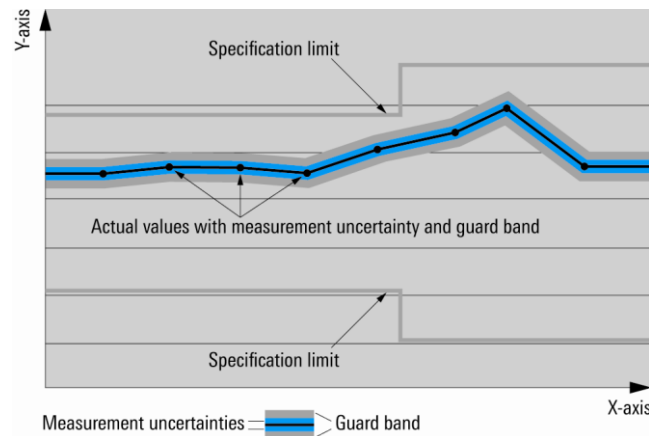

Specifications without limits

Represent warranted product performance for the specified parameter. These specifications are not specially marked and represent values with no or negligible deviations from the given value (e.g. dimensions or resolution of a setting parameter). Compliance is ensured by design.

Typical data (typ.)

Characterizes product performance by means of representative information for the given parameter. When marked with $<$, $>$ or as a range, it represents the performance met by approximately 80 % of the instruments at production time. Otherwise, it represents the mean value.

Nominal values (nom.)

Characterize product performance by means of a representative value for the given parameter (e.g. nominal impedance). In contrast to typical data, a statistical evaluation does not take place and the parameter is not tested during production.

Measured values (meas.)

Characterize expected product performance by means of measurement results gained from individual samples.

Uncertainties

Represent limits of measurement uncertainty for a given measurand. Uncertainty is defined with a coverage factor of 2 and has been calculated in line with the rules of the Guide to the Expression of Uncertainty in Measurement (GUM), taking into account environmental conditions, aging, wear and tear.

Device settings and GUI parameters are indicated as follows: "parameter: value".

Typical data as well as nominal and measured values are not warranted by Rohde & Schwarz.

Specifications

Measurement range

Impedance		50 Ω
Test port connector		N female
Number of test ports		2
Frequency range	R&S [®] ZNLE3	1 MHz to 3 GHz
	R&S [®] ZNLE6	1 MHz to 6 GHz

Static frequency accuracy		(time since last adjustment \times aging rate) + temperature drift + calibration accuracy
Aging per year		$\pm 1 \times 10^{-6}$
Temperature drift (+5 °C to +40 °C)		$\pm 1 \times 10^{-6}$
Achievable initial calibration accuracy		$\pm 5 \times 10^{-7}$

Frequency resolution		1 Hz
Number of measurement points	per trace	1 to 5001
Measurement bandwidth	1/1.5/2/3/5/7 steps	1 Hz to 500 kHz

Dynamic range ¹ of the R&S [®] ZNLE3 and R&S [®] ZNLE6	1 MHz to 50 MHz	specification > 100 dB	typical 110 dB
	50 MHz to 6 GHz	> 110 dB	120 dB

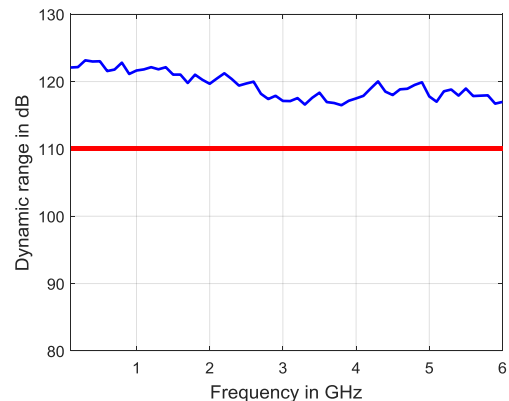
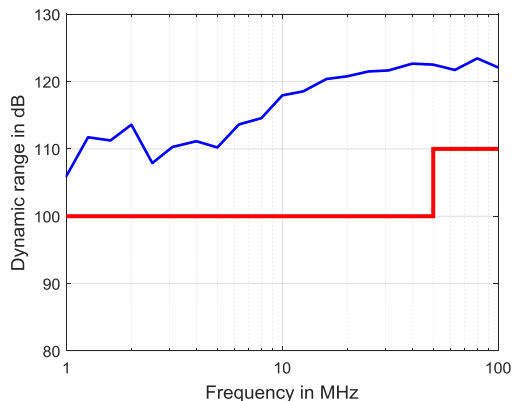

Dynamic range in dB versus frequency for the R&S[®]ZNLE.

¹ The dynamic range is defined as the difference between 0 dBm source power and the RMS value of the data trace of the transmission magnitude, which is produced by noise and crosstalk with the test ports short-circuited. The specification applies at 10 Hz measurement bandwidth, without system error correction. The dynamic range can be increased by using a measurement bandwidth of 1 Hz.

Measurement speed

Measured with firmware version 1.00 and Windows 10, 64-bit.

Measurement time	for 201 measurements points, with 200 MHz span, 500 kHz measurement bandwidth		
	with 900 MHz center frequency	T_{SWEEP} < 4.0 ms	T_{CYCLE} < 5.0 ms
Acquisition time per point (T_{ACQ})	500 kHz measurement bandwidth, CW mode	< 10 μ s	
Sampling time per point (T_{SAMPLE}) IF filter: normal	at 500 kHz measurement bandwidth	4.5 μ s	
Time for measurement and data transfer	for 201 measurements points, with 800 MHz start frequency, 1 GHz stop frequency, 500 kHz measurement bandwidth ²	IEC/IEEE	VXI11 over 1 Gbit/s LAN
		typ. 10 ms	typ. 10 ms
Data transfer time	for 201 measurements points (magnitude)	typ. 3 ms	typ. 2.5 ms
Switching time between channels	with a maximum of 2001 points	< 5 ms	
Switching time between two preloaded instrument settings	with a maximum of 2001 points	< 5 ms	

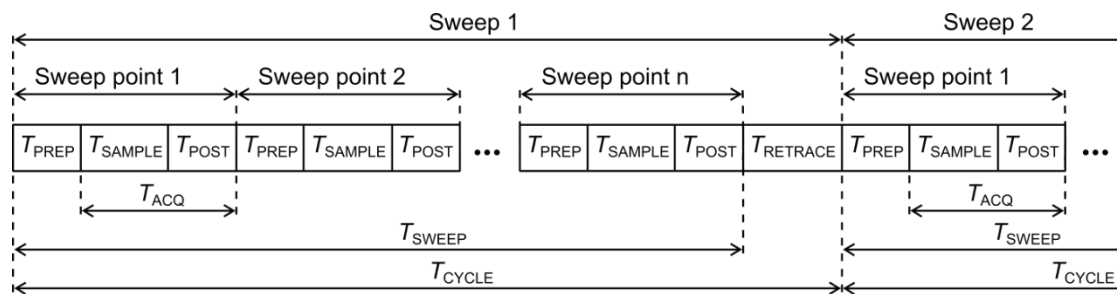

- T_{PREP} Preparation time required to set up the internal hardware components
- T_{SAMPLE} Sampling time (approximately equal to the settling time of the digital filters)
- T_{POST} Time required for hardware postprocessing
- T_{ACQ} Acquisition time ($T_{\text{SAMPLE}} + T_{\text{POST}}$)
- T_{SWEEP} Time required for one sweep
- T_{RETRACE} Time between two sweeps
- T_{CYCLE} Sweep cycle time ($T_{\text{SWEEP}} + T_{\text{RETRACE}}$)

Measurement sequence.

Typical sweep times versus number of measurement points ³ of the R&S®ZNLE3 and the R&S®ZNLE6					
Number of measurement points	51	201	401	1601	5001
800 MHz start frequency, 1 GHz stop frequency, 100 kHz measurement bandwidth					
With correction switched off	2.4 ms	4.9 ms	8.7 ms	31.2 ms	94 ms
With 2-port TOSM calibration	3.9 ms	9.6 ms	16.7 ms	61.7 ms	189 ms
800 MHz start frequency, 1 GHz stop frequency, 1 kHz measurement bandwidth					
With correction switched off	66 ms	258 ms	515 ms	2055 ms	6400 ms
With 2-port TOSM calibration	132 ms	515 ms	1028 ms	4100 ms	12780 ms
100 MHz start frequency, 3 GHz stop frequency, 100 kHz measurement bandwidth					
With correction switched off	3.9 ms	9.1 ms	14.5 ms	36.7 ms	102 ms
With 2-port TOSM calibration	7.3 ms	17.7 ms	28.8 ms	73.3 ms	206 ms
100 MHz start frequency, 3 GHz stop frequency, 1 kHz measurement bandwidth					
With correction switched off	68 ms	262 ms	519 ms	2055 ms	6390 ms
With 2-port TOSM calibration	136 ms	524 ms	1040 ms	4110 ms	12800 ms
100 MHz start frequency, 6 GHz stop frequency, 100 kHz measurement bandwidth					
With correction switched off	3.9 ms	9.5 ms	15.4 ms	47 ms	104 ms
With 2-port TOSM calibration	7.3 ms	18.8 ms	30.5 ms	95 ms	209 ms
100 MHz start frequency, 6 GHz stop frequency, 1 kHz measurement bandwidth					
With correction switched off	68 ms	263 ms	521 ms	2070 ms	6400 ms
With 2-port TOSM calibration	136 ms	525 ms	1042 ms	4120 ms	12800 ms

² In continuous mode, no additional time for data transfer is needed as this occurs simultaneously during the measurement.

³ Sweep time is to be understood as cycle time; static frequency accuracy of the instrument applies; measured with firmware version 1.00, Windows 10.

Measurement accuracy

This data is valid between +18 °C and +28 °C, provided the temperature has not varied by more than 1 °C since calibration. Validity of the data is conditional on the use of an R&S®ZV-Z270 calibration kit and TOSM/SOLT calibration. This calibration kit is used to achieve the effective system data specified below. Frequency points, measurement bandwidth and sweep time have to be identical for measurement and calibration (no interpolation allowed).

Accuracy of transmission measurements		
Above 1 MHz	+5 dB to -35 dB	< 0.05 dB or < 0.5°
	-35 dB to -50 dB	< 0.1 dB or < 1°
	-50 dB to -65 dB	< 0.2 dB or < 2°
Specifications are based on a matched DUT, a measurement bandwidth of 10 Hz and a nominal source power of -10 dBm.		

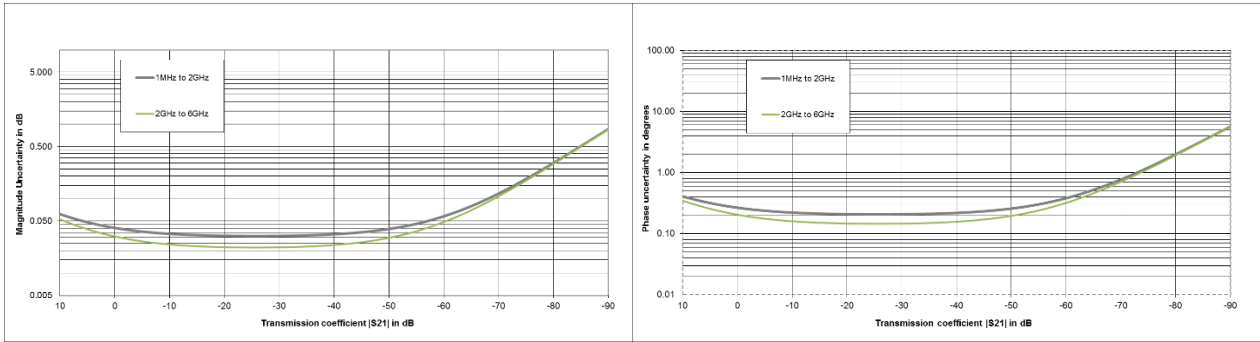

Typical accuracy of transmission magnitude and transmission phase measurements for the R&S®ZNLE3 in the frequency range from 1 MHz to 3 GHz, for the R&S®ZNLE6 in the frequency range from 1 MHz to 6 GHz.
Analysis conditions: $S_{11} = S_{22} = 0$, cal. power -10 dBm, meas. power -10 dBm.

Accuracy of reflection measurements	logarithmic		linear	
		magnitude	phase	magnitude
1 MHz to 6 GHz	0 dB	≤ 0.20 dB	≤ 1.3°	0 dB to -3 dB
	-3 dB	≤ 0.20 dB	≤ 1.3°	< -3 dB to -6 dB
	-6 dB	≤ 0.25 dB	≤ 1.5°	< -6 dB to -15 dB
	-15 dB	≤ 0.58 dB	≤ 4.0°	< -15 dB to -25 dB
	-25 dB	≤ 1.80 dB	≤ 13°	< -25 dB to -35 dB
	-35 dB	≤ 4.50 dB	≤ 42°	
Specifications are based on an isolating DUT, a measurement bandwidth of 10 Hz and a nominal source power of -10 dBm.				

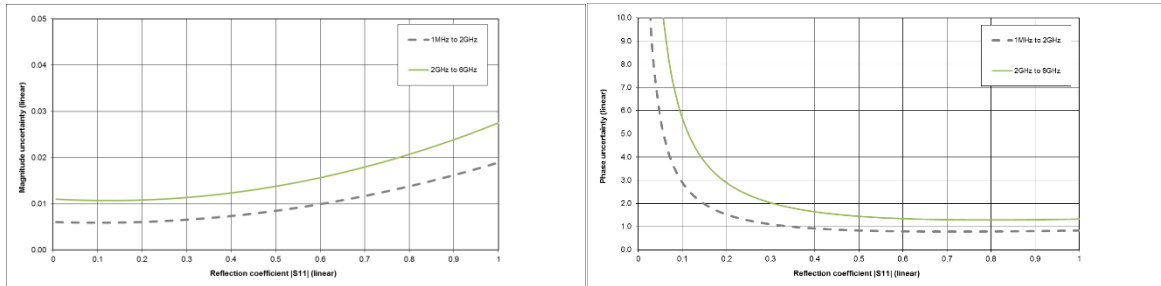

Typical accuracy of reflection magnitude and reflection phase measurements for the R&S®ZNLE3 in the frequency range from 1 MHz to 3 GHz, for the R&S®ZNLE6 in the frequency range from 1 MHz to 6 GHz.
Analysis conditions: $S_{12} = S_{21} = 0$, cal. power -10 dBm, meas. power -10 dBm.

Effective system data

This data is valid between +18 °C and +28 °C, provided the temperature has not varied by more than 1 °C after calibration. Frequency points, measurement bandwidth and sweep time have to be identical for measurement and calibration (no interpolation allowed).

The data is based on a measurement bandwidth of 10 Hz and system error calibration with an R&S®ZV-Z270 calibration kit using TOSM/SOLT with an R&S®ZV-Z270 calibration kit.

R&S®ZNLE3/6	1 MHz to 6 GHz
Directivity	≥ 40 dB
Source match	≥ 36 dB
Load match	≥ 40 dB
Reflection tracking	≤ 0.05 dB
Transmission tracking	≤ 0.05 dB

Factory-calibrated system data

This data is valid between +18 °C and +28 °C. It is based on a source power of -10 dBm and a measurement bandwidth of 1 kHz.

		specification	typical
Directivity	1 MHz to 6 GHz	≥ 20 dB	30 dB
Source match	1 MHz to 6 GHz	≥ 20 dB	30 dB
Reflection tracking	1 MHz to 6 GHz	≤ 1.5 dB	0.5 dB
Transmission tracking	1 MHz to 6 GHz	≤ 1.5 dB	0.5 dB
Load match (raw testport match)	1 MHz to 3 GHz	≥ 14 dB	18 dB
Load match (raw testport match)	3 GHz to 6 GHz	≥ 12 dB	16 dB

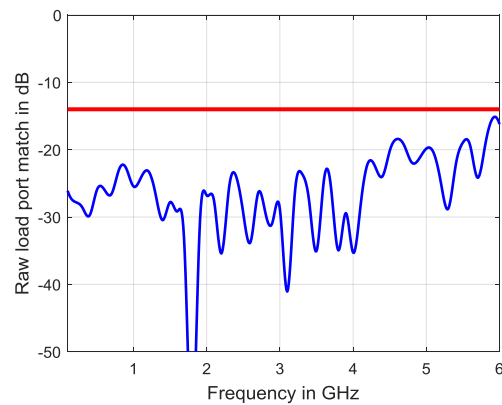
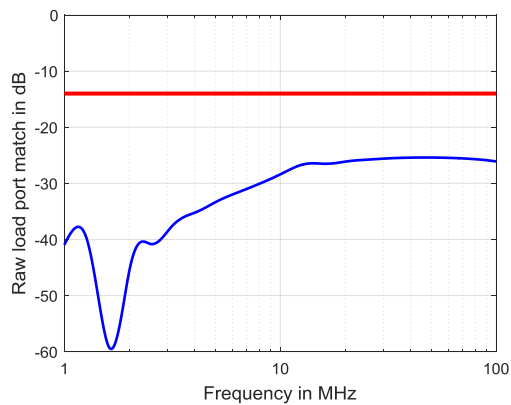

Raw load port match versus frequency for the R&S®ZNLE.

Trace stability		specification	typical
Trace noise magnitude (RMS)	at 0 dBm source power, 0 dB reflection	IF bandwidth	
	1 MHz to 10 MHz	10 kHz	< 0.005 dB 0.001 dB
	10 MHz to 6 GHz	10 kHz	< 0.005 dB 0.001 dB
Trace noise phase (RMS)	at 0 dBm source power, 0 dB reflection	IF bandwidth	
	1 MHz to 10 MHz	10 kHz	< 0.1
	10 MHz to 6 GHz	10 kHz	< 0.05 0.01°
Temperature dependence	at 0 dB transmission or reflection		
	1 MHz to 6 GHz	magnitude phase	0.05 dB/K 0.8°/K

Test port output

This data is valid from +18 °C to +28 °C.

		specification	typical
Power range of the R&S®ZNLE3	1 MHz to 3 GHz	-10 dBm to 0 dBm	up to +2 dBm
Power range of the R&S®ZNLE6	1 MHz to 6 GHz	-10 dBm to 0 dBm	up to +2 dBm
Power accuracy of the R&S®ZNLE3 and the R&S®ZNLE6 source power -10 dBm	1 MHz to 6 GHz	≤ 2 dB	< 0.5 dB
Power linearity referenced to -10 dBm		≤ 1.5 dB	
Power resolution		0.01 dB	
Harmonics source power -10 dBm	1 MHz to 6 GHz		-30 dBc

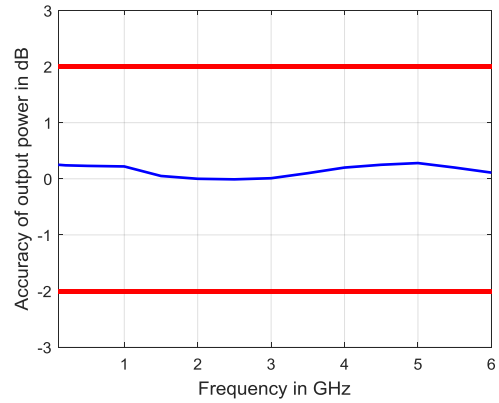
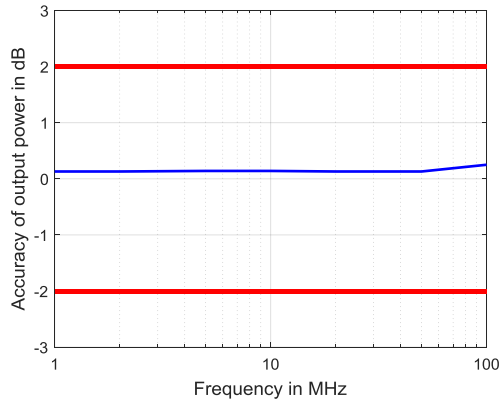

Output power accuracy in dB versus frequency for the R&S®ZNLE base unit.

Test port input

		specification	typical
Maximum nominal input level		0 dBm	
Power measurement accuracy	at -10 dBm without power calibration		
	1 MHz to 6 GHz	< 2 dB	< 0.3 dB
Receiver linearity referenced to -10 dBm	+10 dB to +5 dB	< 0.3 dB	< 0.2 dB
	+5 dB to -40 dB	< 0.2 dB	< 0.1 dB
Damage level		+27 dBm	
Damage DC voltage		30 V	
Noise level at 1 kHz measurement bandwidth, normalized to 1 Hz			
	1 MHz to 50 MHz	< -110 dBm (1 Hz)	-130 dBm (1 Hz)
	50 MHz to 6 GHz	< -120 dBm (1 Hz)	-130 dBm (1 Hz)

The noise level is defined as the RMS value of the specified noise floor.

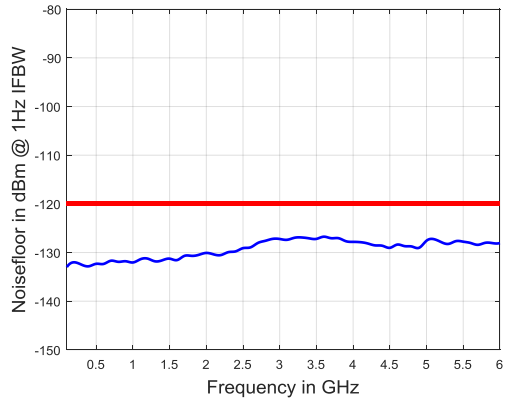
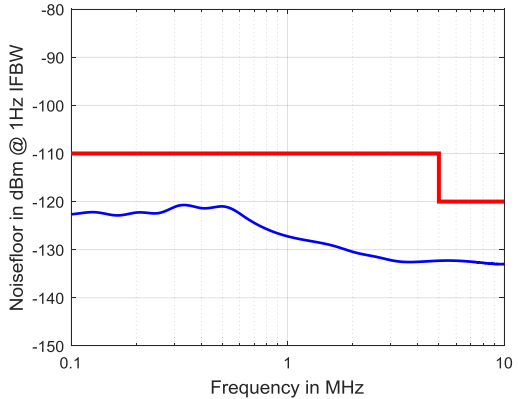

Noise Level in dBm(1 Hz) versus frequency for the R&S®ZNLE.

Additional front panel connectors

USB	two universal serial bus connectors for connecting USB devices (USB 2.0); two additional USB 3.0 connectors on rear panel
-----	--

Display

Screen	26.4 cm (10.1") diagonal WXGA color LCD with touchscreen
Resolution	1280 × 800 × 262144 (high color, 125 dpi)
Pixel failure rate	$< 1 \times 10^{-5}$

Rear panel connectors

LAN	local area network connector, 10/100/1000BASE-T, 8-pin, RJ-45
-----	---

USB	(two) universal serial bus connectors for connecting USB devices (USB 3.0); two additional USB 2.0 connectors on front panel
-----	---

MONITOR	DVI-D connector (for external monitor)
---------	--

REF IN	input for external frequency reference signal	
Connector type		BNC, female
Input frequency		10 MHz
Maximum permissible deviation		1 kHz
Input power		-10 dBm to +15 dBm at 50 Ω
Input impedance		> 10 kΩ

REF OUT	output for external frequency reference signal	
Connector type		BNC, female
Output frequency		10 MHz
Output frequency accuracy		80 Hz
Output power		+6 dBm ± 4 dB at 50 Ω

EXT TRIG IN	trigger input for analyzer	
Connector type		BNC, female
TTL signal (edge-triggered or level-triggered)		3 V, 5 V tolerant
Polarity (selectable)		positive or negative
Minimum pulse width		1 μs
Input impedance		> 10 kΩ

Options

For subsequently activated options, all data sheet parameters are typical values until a calibration is performed.

R&S®FPL1-B10

GPIB interface	remote control interface in line with IEEE 488, IEC 60625; 24-pin
-----------------------	---

General data

Data storage		
Internal	standard	solid-state drive 32 Gbyte (nom.)
External		supports USB-2.0-compatible memory devices

Environmental conditions		
Temperature	operating temperature range	+5 °C to +40 °C
	storage temperature range	-20 °C to +70 °C
Climatic loading		+40 °C at 85 % rel. humidity, in line with EN 60068-2-30, without condensation

Mechanical resistance		
Vibration	sinusoidal	5 Hz to 55 Hz 0.15 mm constant amplitude (1.8 g at 55 Hz); 55 Hz to 150 Hz acceleration: 0.5 g constant; in line with EN 60068-2-6
	random	10 Hz to 300 Hz, acceleration 1.2 g (RMS), in line with EN 60068-2-64
Shock		40 g shock spectrum, in line with MIL-STD-810E Method No. 516.4 Procedure I, MIL-PRF-28800F

EMC		in line with EMC Directive 2014/30/EU including IEC/EN 61326-1 ^{4, 5} , IEC/EN 61326-2-1, CISPR 11/EN 55011 ⁴ , IEC/EN 61000-3-2, IEC/EN 61000-3-3
------------	--	--

Recommended calibration interval		1 year
---	--	--------

Power supply		
AC supply		100 V to 240 V ± 10%, 50 Hz to 60 Hz ± 5%, 400 Hz ± 5% class of protection I in line with VDE 411
Current consumption		1.7 A to 0.8 A
Power consumption		max. 170W, typ. 80 W
Safety		in line with EN 61010-1, IEC 61010-1, UL 61010-1, CAN/CSA-C22.2 No. 61010-1
Test mark		CSA, CSA-NRTL

Dimensions and weight		
Dimensions	W × H × D	408 mm × 186 mm × 235 mm (16.06 in × 7.32 in × 9.25 in)
Net weight, nominal		6 kg (13.22 lb)

⁴ Emission limits for class A equipment.

⁵ Immunity test requirement for industrial environment (EN 61326 table 2).

Dimensions (in mm)

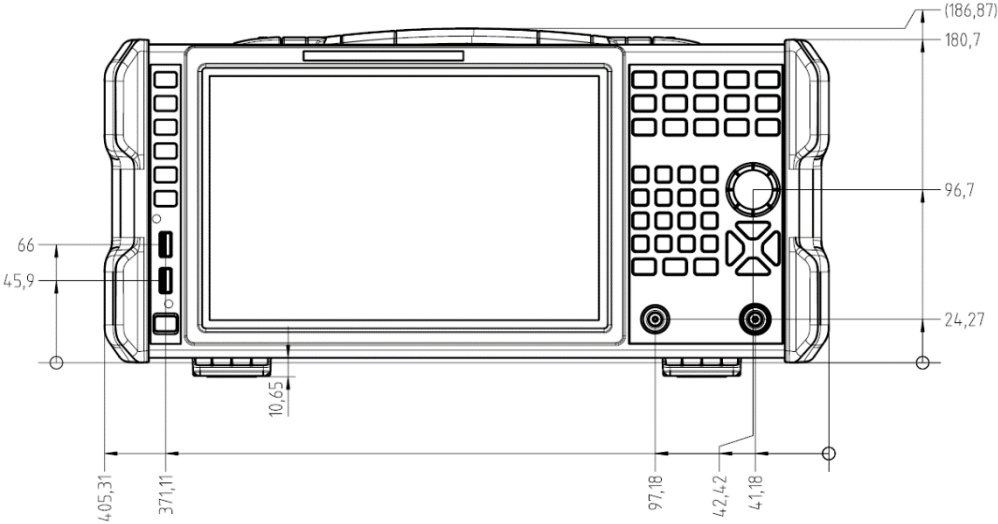

Front view of the R&S®ZNLE.

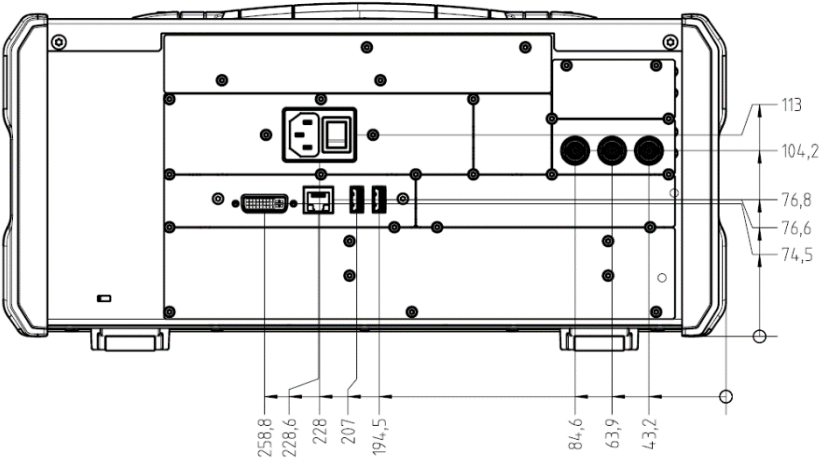

Rear view of the R&S®ZNLE.

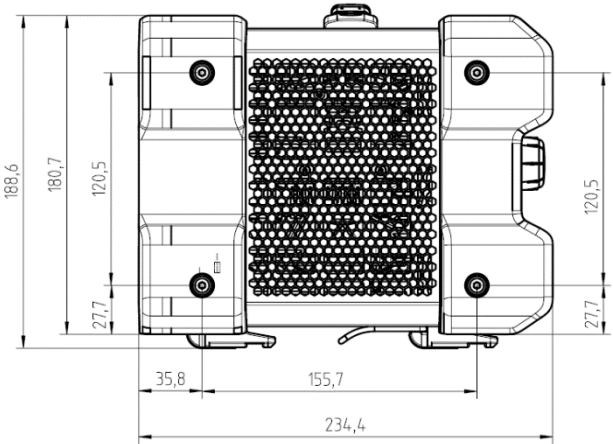

Side view of the R&S®ZNLE.

Ordering information

Designation	Type	Retrofit ⁶	On Site ⁷	Order No.
Base unit				
Vector Network Analyzer, Two Ports, 3 GHz, N	R&S [®] ZNLE3			1323.0012.53
Vector Network Analyzer, Two Ports, 6 GHz, N	R&S [®] ZNLE6			1323.0012.56
Options				
GPIO Interface	R&S [®] FPL1-B10	✓	✓	1323.1890.02

Warranty		
Base unit		3 years
All other items ⁸		1 year
Options		
Extended Warranty, one year	R&S [®] WE1	Please contact your local Rohde & Schwarz sales office.
Extended Warranty, two years	R&S [®] WE2	
Extended Warranty with Calibration Coverage, one year	R&S [®] CW1	
Extended Warranty with Calibration Coverage, two years	R&S [®] CW2	
Extended Warranty with Accredited Calibration Coverage, one year	R&S [®] AW1	
Extended Warranty with Accredited Calibration Coverage, two years	R&S [®] AW2	

Extended warranty with a term of one and two years (WE1 and WE2)

Repairs carried out during the contract term are free of charge ⁹. Necessary calibration and adjustments carried out during repairs are also covered.

Extended warranty with calibration coverage (CW1 and CW2)

Enhance your extended warranty by adding calibration coverage at a package price. This package ensures that your Rohde & Schwarz product is regularly calibrated, inspected and maintained during the term of the contract. It includes all repairs ⁹ and calibration at the recommended intervals as well as any calibration carried out during repairs or option upgrades.

Extended warranty with accredited calibration (AW1 and AW2)

Enhance your extended warranty by adding accredited calibration coverage at a package price. This package ensures that your Rohde & Schwarz product is regularly calibrated under accreditation, inspected and maintained during the term of the contract. It includes all repairs ⁹ and accredited calibration at the recommended intervals as well as any accredited calibration carried out during repairs or option upgrades.

⁶ Option may also be ordered at a later stage, upgrade in service.

⁷ Option may be installed by the customer on site.

⁸ For options that are installed, the remaining base unit warranty applies if longer than 1 year.

⁹ Excluding defects caused by incorrect operation or handling and force majeure. Wear-and-tear parts are not included.

Service that adds value

- ▮ Worldwide
- ▮ Local and personalized
- ▮ Customized and flexible
- ▮ Uncompromising quality
- ▮ Long-term dependability

Rohde & Schwarz

The Rohde & Schwarz electronics group offers innovative solutions in the following business fields: test and measurement, broadcast and media, secure communications, cybersecurity, monitoring and network testing. Founded more than 80 years ago, the independent company which is headquartered in Munich, Germany, has an extensive sales and service network with locations in more than 70 countries.

Sustainable product design

- ▮ Environmental compatibility and eco-footprint
- ▮ Energy efficiency and low emissions
- ▮ Longevity and optimized total cost of ownership

Certified Quality Management

ISO 9001

Certified Environmental Management

ISO 14001

Rohde & Schwarz GmbH & Co. KG

www.rohde-schwarz.com

Rohde & Schwarz training

www.training.rohde-schwarz.com

Regional contact

- ▮ Europe, Africa, Middle East | +49 89 4129 12345
customersupport@rohde-schwarz.com
- ▮ North America | 1 888 TEST RSA (1 888 837 87 72)
customer.support@rsa.rohde-schwarz.com
- ▮ Latin America | +1 410 910 79 88
customersupport.la@rohde-schwarz.com
- ▮ Asia Pacific | +65 65 13 04 88
customersupport.asia@rohde-schwarz.com
- ▮ China | +86 800 810 82 28 | +86 400 650 58 96
customersupport.china@rohde-schwarz.com

Thurlby Thandar Instrument Distribution
Glebe Road, Huntingdon, PE29 7DR, UK
+44 (0)1480 412 451
sales@ttid.co.uk
www.ttid.co.uk



R&S® is a registered trademark of Rohde & Schwarz GmbH & Co. KG
Trade names are trademarks of the owners
PD 5215.1882.22 | Version 02.00 | July 2017 (we)
R&S®ZMLE Vector Network Analyzer
Data without tolerance limits is not binding | Subject to change
© 2017 Rohde & Schwarz GmbH & Co. KG | 81671 Munich, Germany



5215188222