

# ITECH TEST SOLUTION PV and Energy Storage

YOUR POWER  
TESTING  
SOLUTION

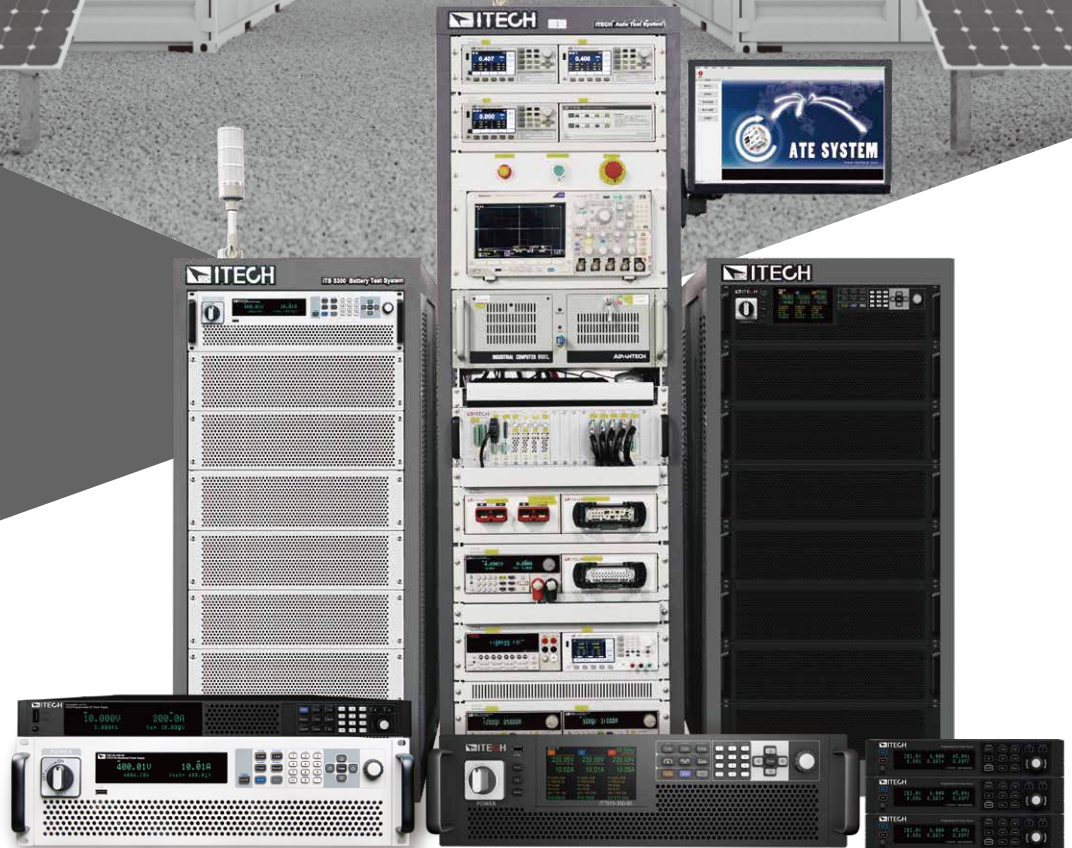



# New power grid structure

## -Wind power + solar power + energy storage

In the last 20 years, global warming and glacial melting have shown that climate change brought about by the greenhouse effect is seriously affecting the living environment of human beings. As countries around the world gradually pay attention to global climate change, several carbon emission reduction measurements such as net-zero carbon emissions are gradually being implemented. Countries are making great efforts to build a new type of power system with renewable energy as the mainstay. The new power system features as the dominance of wind power and solar power in the power supply structure. The power grid will develop into a "grid + active distribution network + micro-grid".

Due to the seasonal, intermittent and fluctuating nature of renewable energy power generation, it faces challenges in terms of continuous and reliable power supply, safety and stability. "Solar power + wind power + energy storage" has become a mainstream power system model. Energy storage systems can greatly alleviate the instability of power generation and provide a fast energy buffer for the grid, thus keeping the voltage and frequency of the grid stable, so the role of energy storage technology in the new grid industry is increasingly prominent.

ITECH provides professional testing solutions for global renewable energy development. Currently, ITECH offers a new generation of grid simulators, battery simulators, PV simulators, AC/DC electronic loads and bidirectional DC power supplies with high power density, high speed and energy regeneration for tests of renewable power generation. In addition, ITECH offers the solar array simulation SAS1000 and the energy storage battery characteristic curve simulation software BSS2000, which reproduces the real power generation curve waveform. Its modular design and flexible power extension allow you to switch freely between low-power string inverters and high-power grid-connected inverters. You do not need to purchase test equipment repeatedly, saving costs largely.

### Achieve carbon dioxide peaking

It refers to the point in time in which greenhouse gas emissions will shrink in each following year, until it reaches emissions levels we deem to be safe.

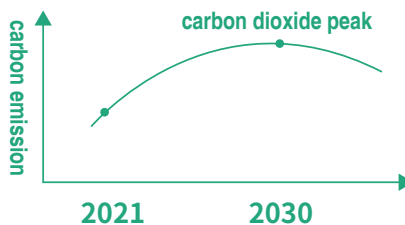

### Carbon neutrality commitment by 2050

EU UK Japan Korea Canada  
France Germany Hungary South Africa Spain

### China

Achieve carbon dioxide peaking by 2030  
Carbon neutrality commitment by 2060

### Net-zero emission

It refers to a state of net-zero carbon dioxide emissions. This can be achieved by balancing emissions of carbon dioxide with its removal or by eliminating emissions from society.

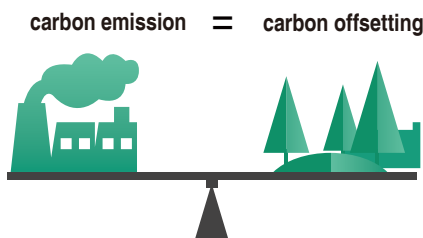

### Carbon net-zero emission commitment by 2045

Sweden



### Carbon net-zero emission commitment by 2040

Austria

## ITECH Test Solution - PV inverter

As a core equipment of PV power generation system, the PV inverter is to convert the variable DC voltage generated by PV modules into AC power, which is one of the important system balances in solar array system. At present, the common inverters on the market are mainly centralized inverters, string inverters and micro inverters.

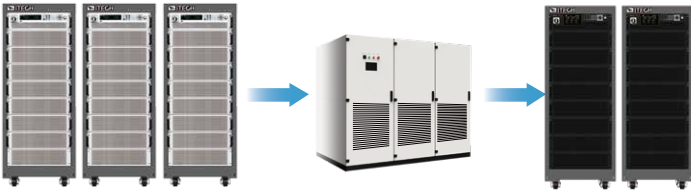
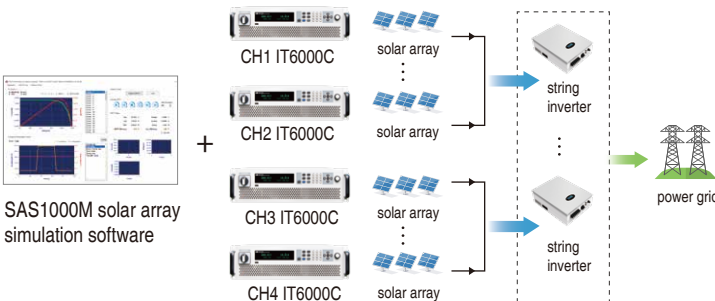
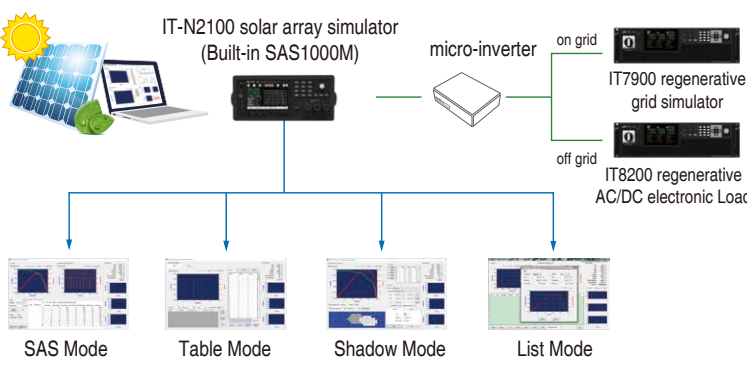
One of the important indicators of inverter performance is the efficiency of maximum power point tracking. The higher the efficiency, the higher the conversion utilization of solar energy. In practical applications, the PV power is affected by the sunlight intensity, and the sunlight is strongly correlated with climate, season and region, and the variation is extremely obvious and random even within one day. Therefore, in order to fully verify the MPPT efficiency of the inverter under various conditions, you need a high-performance PV simulator to complete the test.

ITECH Test Solution - PV inverter	Recommend product - PV simulator
<p><b>Centralized inverters test</b></p>  <p>IT6600PV → centralized inverters → IT7900E/IT7900 regenerative grid simulator</p>	<p><b>IT6600PV</b></p> <ul style="list-style-type: none"> <li>• 42kW in 3U height, Pmax.10MW, no loss after parallel connection</li> <li>• Voltage: 600V/2250V</li> <li>• Dynamic response: &lt;2ms</li> </ul> <p><b>Solar array simulation software (single channel)</b></p> <ul style="list-style-type: none"> <li>• Simulation of I-V curves under different temperature/irradiation/shading conditions</li> <li>• Provide different curve editing modes such as built-in regulation/Table/Program/List mode</li> <li>• Real-time display of MPPT efficiency</li> </ul>
<p><b>String inverters test</b></p>  <p>SAS1000M solar array simulation software + CH1 IT6000C, CH2 IT6000C, CH3 IT6000C, CH4 IT6000C → solar array → string inverter → power grid</p>	<p><b>IT6000C high power bidirectional DC power supply</b></p> <ul style="list-style-type: none"> <li>• 18kW in 3U height, Pmax.2MW, no loss after parallel connection</li> <li>• Voltage: 800V/1500V/2250V</li> <li>• Fast MPPT current response, up to 4us, adapt to high-speed algorithms</li> <li>• Built-in IV curve simulation, four-point method (Voc/Isc/Vmp/Imp) for fast curve generation</li> </ul> <p><b>SAS1000 solar array simulation software (multiple channels)</b></p> <ul style="list-style-type: none"> <li>• Support up to 20 channels MPPT test</li> <li>• 20 channels can be controlled independently and synchronously, easy to operate</li> <li>• Support MPPT testing under dynamic/static/different regulations</li> </ul>
<p><b>Micro-inverters test</b></p>  <p>IT-N2100 solar array simulator (Built-in SAS1000M) → micro-inverter → on grid IT7900 regenerative grid simulator, off grid IT8200 regenerative AC/DC electronic Load</p> <p>SAS Mode, Table Mode, Shadow Mode, List Mode</p>	<p><b>IT-N2100 solar array simulator</b></p> <ul style="list-style-type: none"> <li>• Ultra-compact, only 2U half-rack for single channel, up to 64 channels of synchronous control</li> <li>• Single-channel power up to 1500 W</li> <li>• Output isolation voltage up to 1500V</li> <li>• Low output impedance for fast dynamic response, adaptable to high speed MPPT speed of inverter</li> <li>• Support high voltage resistant topology, support DUTs series test</li> </ul> <p><b>SAS1000M(multi-channel) solar array simulation software</b></p> <ul style="list-style-type: none"> <li>• Multi-channel SAS supports MPPT testing of 20 DUTs</li> <li>• Simulation of output characteristics of various solar cells (monocrystalline/polysilicon/thin film)</li> <li>• Support dynamic/static MPPT testing under different regulatory standards</li> </ul>
<p><b>Power optimizer test</b></p>  <p>IT-N2100 solar array simulator → power optimizer (MPPT DC-DC) → IT-M3800 regenerative DC electronic load</p>	<p><b>IT-N2100 solar array simulator</b></p> <ul style="list-style-type: none"> <li>• Two levels of output voltage: 80V and 150V</li> <li>• High-definition screen, real-time curve display, standard solar array simulation software</li> <li>• High-speed current dynamic response, supporting high-speed MPPT</li> <li>• Support dynamic/static MPPT testing under different regulatory standards</li> </ul>

# MPPT Test

## Graphical PV simulation software (SAS1000)

ITECH high speed and high performance solar array simulation software has a graphical interface, you can easily output, measure and display the MPPT status and record the test data of PV inverters in real time. It has 5 built-in regulatory tests such as EN50530, Sandia, etc. to test the static and dynamic MPPT performance of PV inverters and generate reports. The software also provides Shadow and Table modes, you can input a matrix of 128~4096 points to edit any shielded I-V curve to achieve dynamic cloud shading effect. In addition, it can also store 100 I-V curves under different irradiation and temperature to test the long-term maximum power tracking performance of PV inverters under different climatic conditions.

## Features

- Solar array simulate I-V function (Built-in I-V curve mathematical formula)
- Support up to 20 solar cell power supplies for multi-channel MPPT testing (SAS1000M)
- Simulate the output characteristics of various solar cell (monocrystalline silicon cell, polysilicon cell, thin film cell) (Fill Factor)
- Simulate I-V curve for solar panel under shadow
- Static & dynamic MPPT efficiency test
- Built-in EN50530 / Sandia / NB/T32004 / CGC/GF004 / CGC/GF035 test program, and generate reports
- Auto program control 100 I-V curves via Voc, Isc, FF, Pm and other parameter points \*1
- 100 \* 128 points curves and 4096 points precise programming control \*1
- Support four-point method switching \*2
- List function
- Online modification of temperature, irradiation and other parameters, real-time adjustment of the I-V curve

\*1 IT-M3600 supports 10 curves and 1024 points control in Table mode

\*2 Not available for IT65000

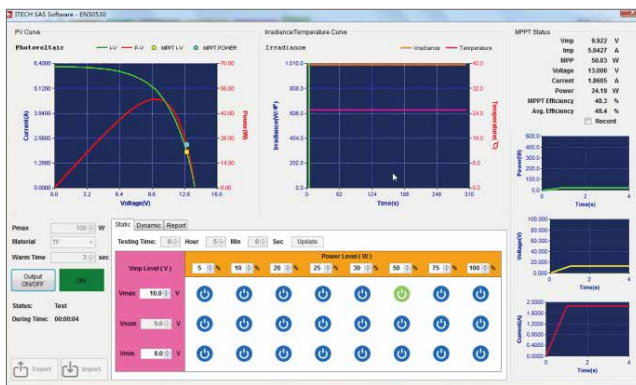

Static&Dynamic MPPT test

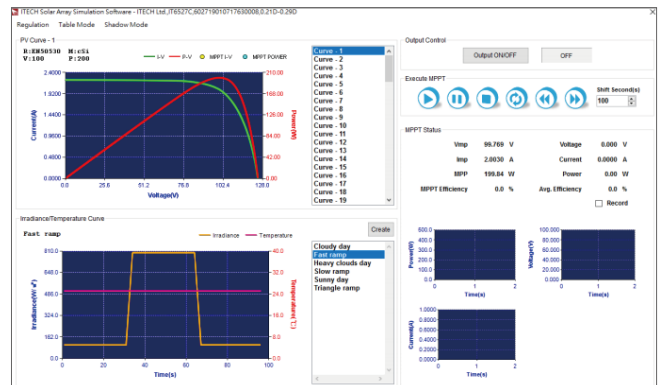

Simulation of I-V curves at different temperatures/irradiation

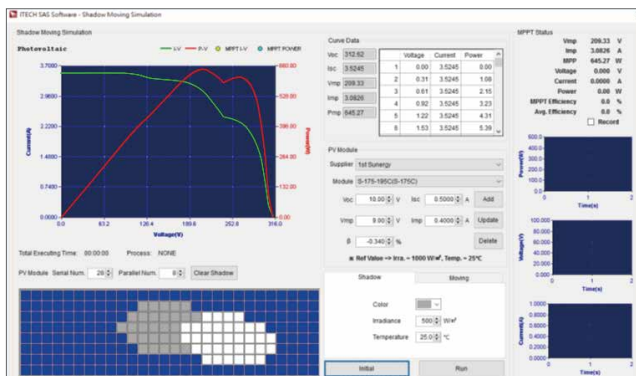

Shielded I-V curve simulation(Shadow Mode)



Multi-channel MPPT test

# MPPT Test

**Product** IT7900/IT7900PIT7900E/IT7900EP regenerative grid simulator  
16Hz~150Hz, 2kVA~1MVA+

**Application** Grid connected regulatory compliance testing of inverters, power storage converters, wind power converters, etc.

**Regulation compliance** IEEE1547、IEC62116、VDE-AR-N 4105、EN50549

The IT7900 regenerative grid simulator can simulate grid anomalies such as voltage deviation, frequency deviation, frequency change rate, three-phase voltage unbalance, voltage fluctuation, harmonic disturbance and phase angle jump, which are good for grid adaptability testing.



IT7900/IT7900PIT7900E/IT7900EP regenerative grid simulator

## Features

- Regenerative grid simulator & full 4-Quadrant AC&DC power sources
- No need to switch between high and low voltage, higher current output can be achieved at low voltages
- Compliance tests incl Phase Jump/Frequency variation/Harmonic Injection
- Single/three-phase output, can simulate three-phase unbalanced/missin phase output
- Power line disturbance simulation testing by LIST programming/SWEEP/-Surge&Sag functions
- Professional anti-islanding test mode, can set and simulate the RLC(resis-tive-inductive-capacitive), active and reactive power circuit for anti-islanding detection
- The harmonic measurement function can measure 50th order harmonics of voltage and current(50-60Hz)
- Provides various trigger input/output signals. When amplitude/frequency changes, trigger signals can be generated to synchronously capture the current waveform of DUTs
- IT7900P/IT7900EP can be also used as an AC load, applied to the output test of off-grid inverters

<b>Voltage adaptability test</b>	<b>Frequency adaptability test</b>	<b>Electrical energy adaptability test</b>	<b>Voltage ride through</b>	<b>Anti-islanding test</b>
Voltage dips Interruption voltage fluctuation Flicker three-phase unbalance DC component injection Phase angle jump	Frequency disturbance Under/over frequency protection	Superimposed harmonic disturbance Interharmonic injection	HVRT LVRT	Islanding protection test

## Built-in anti-islanding mode

- which simplifies the test
- Parameters like P QL Qc or R L C can be set individually for each phase
- Islanding protection time can be measured

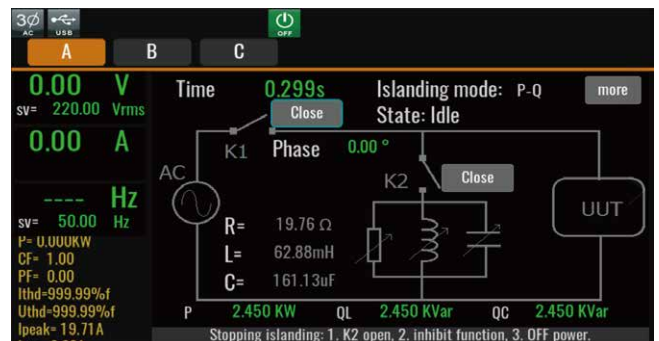

IT7900 Anti-islanding test

# | ITECH Test Solution - Energy Storage

## Test of Power Conversion System (PCS)

As the proportion of renewable energy generation in the overall energy structure continues to rise, the demand for construction of energy storage facilities on the power generation side will achieve rapid growth. ITECH has rich solutions in the field of energy storage, covering tests of PCS, energy storage battery systems and so on.

Different from traditional test solutions, ITECH test instruments are with high power density, regenerative and bidirectional, which are very suitable for the applications in the field of energy storage. Moreover, the powerful waveform editing and high-precision measurement functions help you to easily realize various grid-connected regulation tests (anti-islanding test, LVRT, HVRT, frequency disturbance, phase angle jump, etc.) without the need for additional equipment, reducing test costs and improving efficiency.

### ITECH test solution for energy storage system

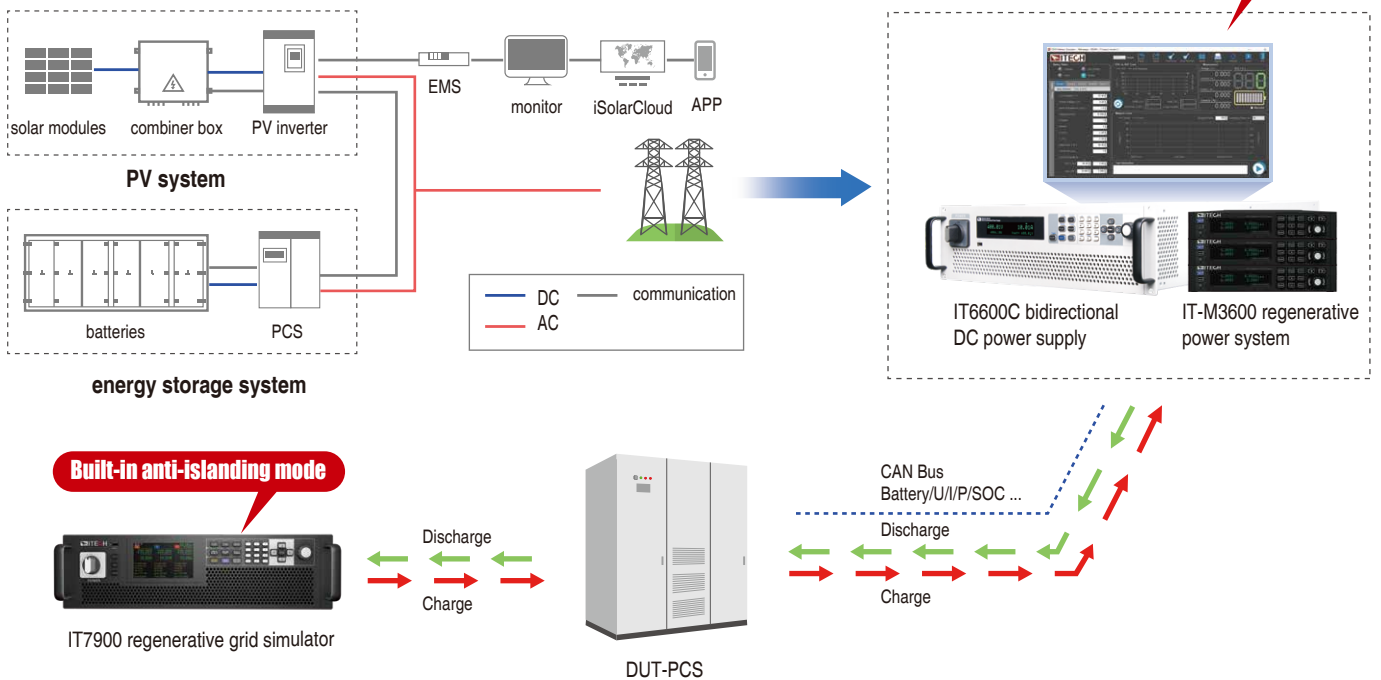

Model	Advantage	Test item
<b>Battery simulator</b> IT6000C+BSS2000 IT6600C	Modular design, 42kW in 3U height, power extended to 10MW after parallel connection Bidirectional and regenerative design, seamless current switching, regenerative efficiency up to 95% Battery simulation software BSS2000, built-in lithium iron phosphate / lithium ternary battery curve Customizable battery initial SOC, initial voltage or initial capacity to enhance testing efficiency Built-in CAN/LAN/USB	Grid-connected overload capability test Frequency adaptability test AC voltage adaptability test DC over/under voltage protection test LVRT Anti-islanding protection performance test
<b>IT7900P /IT7900EP regenerative grid simulator</b>	High power density design, 21kVA in 3U height , power extended to 1MVA+ after parallel connection Voltage range: 350V L-N, 16Hz~2400Hz Grid simulator and regenerative AC load in one Support CC/CR/CP mode Built-in anti-islanding protection test function, simplify wiring and improve test efficiency Simulate the waveform of grid phase loss/three-phase unbalance/harmonic injection/voltage transient drop and frequency disturbance	Grid-connected current harmonics testing PCS input and output testing

## Test of Storage Battery System

**DUT** Test of Storage Battery System

**Product** ITS5300 battery charge and discharge test system  
 IT6000C high power bidirectional DC power supply  
 IT6600C

With advanced bidirectional regenerative DC power modules and flexible master-slave parallel technology, ITECH can provide you with high-power test solutions up to 2MW for energy storage battery system testing. With professional software, it can realize stable and reliable charge-discharge cycle life test.

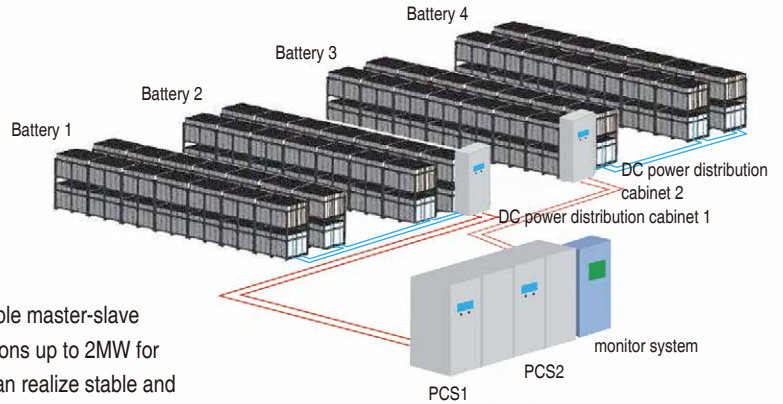

### Modular design

- Modular design, matched with temperature logger internal resistance analyzer, thermostat, etc.
- Flexible paralleling between channels to extend power
- High power density design enables MW-scale battery test solutions

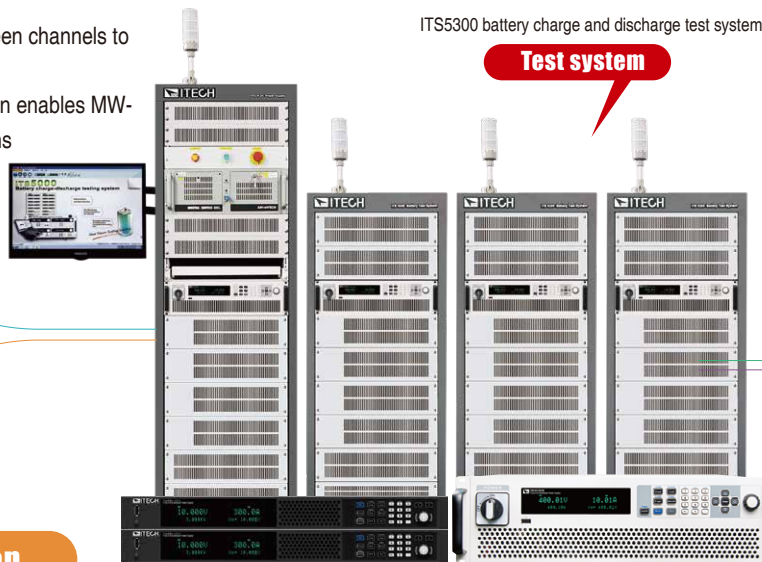

### Full protection

- Anti-crash after power failure
- Anti-reverse connection and anti-sparking
- Emergency stop
- Power abnormal protection
- Overcharge/overdischarge/overtemperature protection

### Test item

- Constant power charge and discharge test
- Constant current charge and discharge test
- Cyclic charge-discharge performance test
- Overcharge and overdischarge rate test
- Charge and discharge test under high/low temperature

### Multiple list steps

- CC/CV/CP/CR/Pulse
- Driving simulation under real road conditions, max.10 million points can be edited
- Goto and loop function
- Bms communication, support .Dbc file import
- Statistical analysis and data reporting
- Fast sampling, up to 1ms

### Bidirectional with current seamless switching, regenerative

- Both source and sink, regeneration efficiency is up to 95%max.
- -90%~90% current, less than 2ms of switching

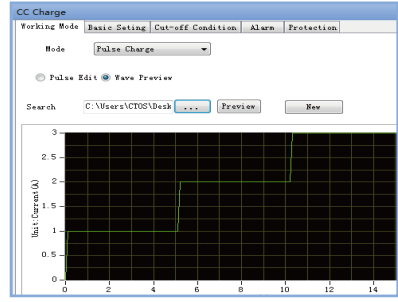

# Household photovoltaic energy storage device test

With the goal of zero carbon emissions, home energy storage technology has gradually developed. The smart home energy storage system is similar to a micro energy storage power station, and its operation is not restricted by the public grid. During low power consumption period, the lithium-ion battery pack in the home energy storage system can be self-charged to be used for backup power peaks or power outages. In addition to being used as an emergency power source, the smart home energy storage system can also save electricity expenses because it can balance the electricity consumption.

## Test solution

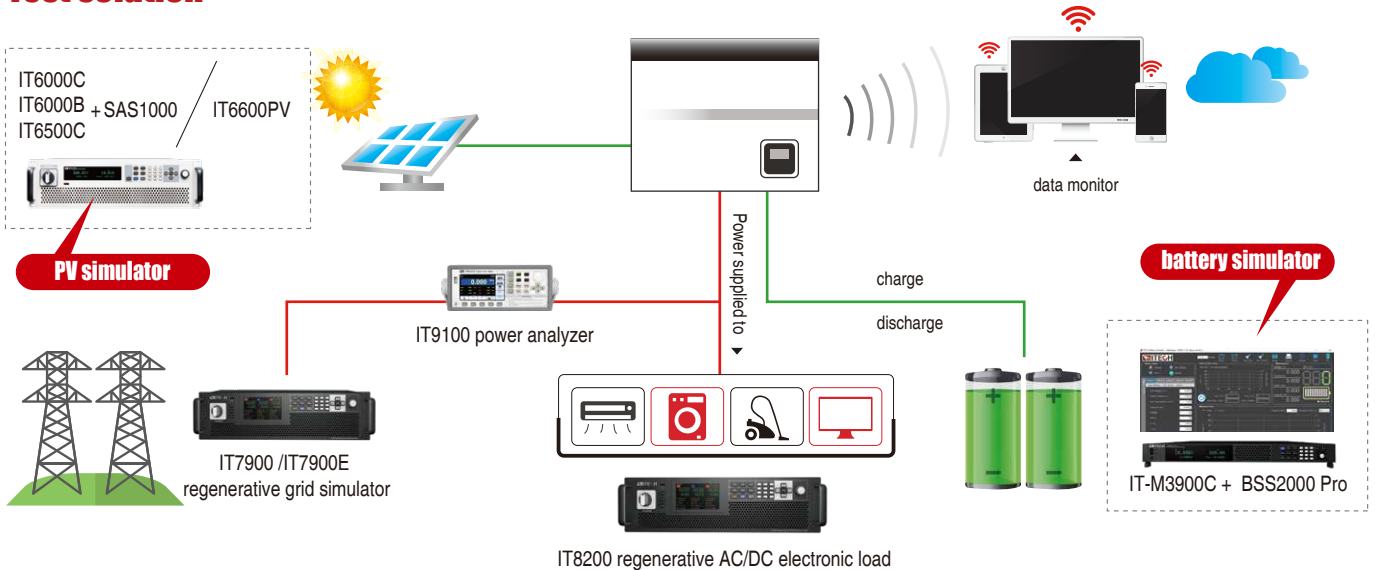

## Advantages

ITECH provides battery simulators, PV simulators and grid simulators for testing of household PV energy storage devices. You can achieve remote control and data access to the test instruments through the built-in CAN/LAN interface. Thanks to the rich waveform editing functions, you can quickly simulate grid disturbance, harmonic injection, frequency disturbance, etc. At the same time, ITECH provides solar array simulation software (SAS1000) and battery simulation software (BSS2000) to simulate the real characteristic curves of solar cells and batteries in the real environment. You can quickly set the initial SOC of the energy storage battery without charging and discharging the real battery, thereby improving the test efficiency.

Model	Advantage	Test item
<b>Solar Array Simulator</b> IT6000C IT-N2100 IT6600PV	Can be used both as a battery simulator (with BSS2000) and as a PV simulator (with SAS1000) Fast dynamic response <2ms Max. voltage is up to 2250V, max. power is up to 10MW The above are the characteristics of IT6600C series PV simulator Features of IT-N2100 solar array simulator: HD screen, real-time curve; standard solar array simulation software; low input capacitance and current noise; 1500V output voltage isolation.	<ul style="list-style-type: none"> <li>Verify the performance of PV energy storage devices in different mode</li> <li>(solar only, grid first, solar first, Hybrid) Verify the over voltage and under voltage of the DUT, overload</li> <li>protection and short-circuit protection Verify the MPPT efficiency of the DUT</li> <li>Verify the grid-connected performance of the DUT</li> </ul>
<b>Regenerative grid simulator</b> IT7900/IT7900E	High power density design, 3U up to 21kVA in 3U height, power extended to 1MVA+ Built-in anti-islanding protection test function, simplifying wiring and improving test efficiency Simulate phase loss/three-phase unbalance/harmonic injection/voltage transient drop waveforms Clear display of waveform/harmonic/meter measurement results	
<b>Regenerative AC electronic load</b> IT8200	Simulate all kinds of inductive, capacitive and resistive loads Modular design, support single-phase/three-phase mode, flexible switching 3U up to 15kVA, regenerative efficiency is up to 95% max. Graphical waveform and data measurement function, easy to check the test results	



# | Test solution for micro inverter and power optimizer

## IT-N2100 solar array simulator

- Low input capacity, low noise
- Real time curve simulation
- 5 PV modes
- DC output withstand voltage 1500V
- Simulate different temperature and radiation I-V curves under cloud shield

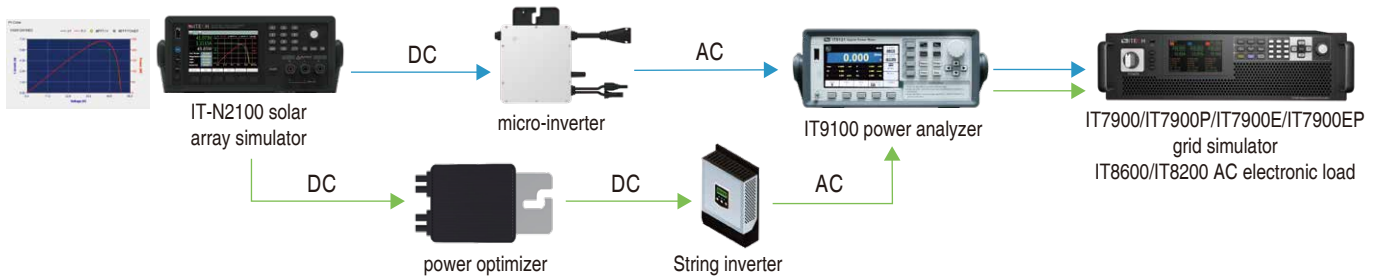

# | Test solution for portable power station

One stop solution	Full protection	PV I-V curve simulation	Modified wave output test	Energy storage test	Fast charging interface test
-------------------	-----------------	-------------------------	---------------------------	---------------------	------------------------------



# | Solar panel I-V curve test

Changes in temperature, irradiation, and sunlight intensity will affect the I-V characteristics and conversion efficiency of solar cells. As the temperature increases, the shape of the I-V curve changes, the fill factor decreases, and the conversion efficiency decreases with the increase of temperature. The light intensity increases, the output power increases, and the conversion efficiency increases. Therefore, the I-V characteristics of solar cells must be captured at multiple points in a short period of time to ensure the accuracy of the test results.

## System architecture & Test items

Parameters

- Ishort
- Vopen
- Pmax
- Vpmax
- Ipmax
- Rpmax
- FF

# ITECH Test Solution - Wind Power Generation

Wind power generation is the conversion of wind energy into electricity. It is one of the important applications of renewable energy. Wind energy resources are mostly concentrated in coastal and open continental shrinkage zones.

The principle of wind power generation is to use the wind to drive the blades of the windmill to rotate, and then increase the speed of the rotation through the speed-increasing machine, promoting the generator to generate electricity. Connected to the wind turbine is the wind energy converter, which ensures that it can generate constant-frequency electricity into the grid when the speed of the fan changes.

## Test solution of wind energy converter

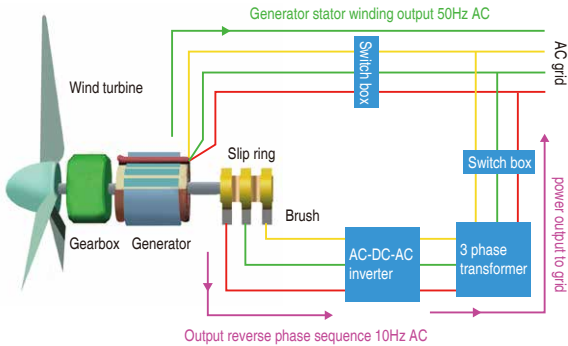

wind turbines work principle

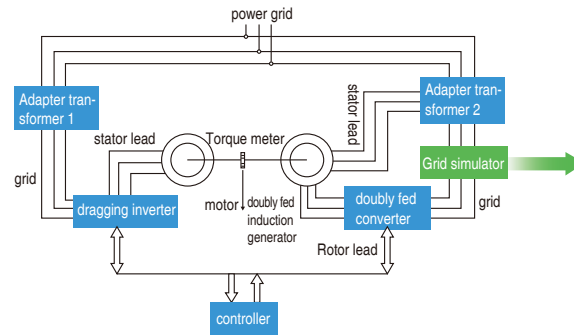

doubly fed converter test platform



IT7900/IT7900E Regenerative grid simulator

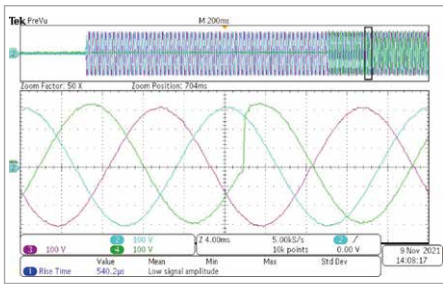

phase angle jump test

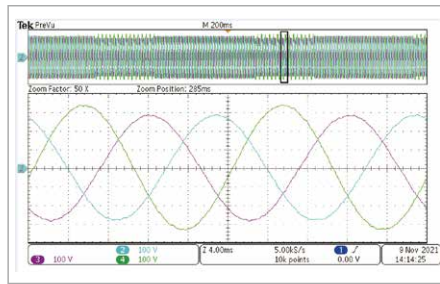

HVRT test

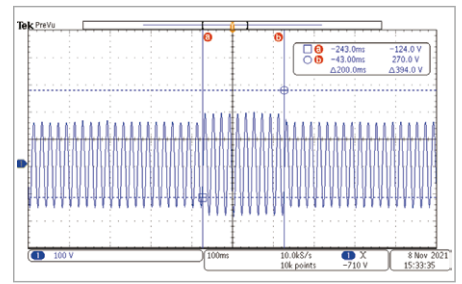

3 phase unbalance test

## Test solution - pitch servo drive

### IT7800/IT7800E High performance AC/DC power supply

- 21kVA in 3U height, power extended to 1MVA+ after parallel connection
- Meet the high voltage/low voltage/grid fluctuation range/frequency fluctuation of the pitch drive range test
- Graphical oscilloscope and data display modes make the test results easy to see



IT7800/IT7800E High performance AC/DC power supply

### DUT: Pitch servo drive

- Normal operation working voltage 320V~540Vac
- Frequency range 45Hz~66Hz
- The propeller can be safely retracted under the condition of 1.7Un

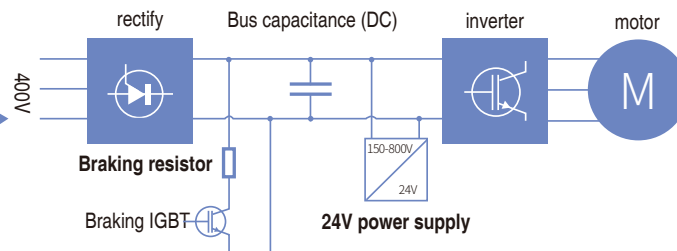

## Test solution - Three-level power conversion system

Since 2018, three-level PCS have emerged, which has become a new trend in the development of wind power converter technologies. Compared with two-level PCS, three-level PCS have lower output harmonic content and higher power conversion efficiency. It helps to increase the grid-connected voltage, thereby reducing cable costs and improving system conversion efficiency.

Three-level PCS testing challenges include grid adaptability testing and DC power supply up to several kilovolts. ITECH high-voltage DC power supply can provide a solution up to 4500V for three-level PCS testing, helping you to complete the test easily.

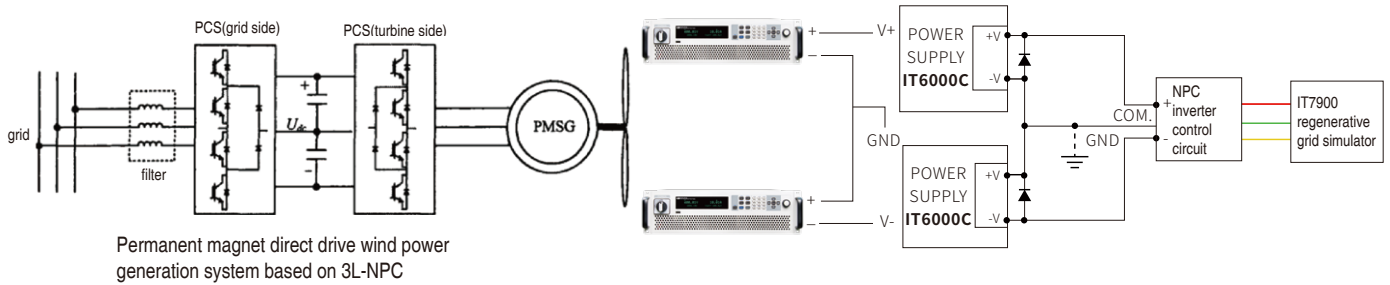

## Hardware-in-the-loop simulation test

Power Hardware in the loop (PHIL) realizes the extension of signal level real-time simulation to power level through the combination of real-time simulator, power amplifier and the DUT. It can be used to test real power equipment, such as energy storage equipment, photovoltaic equipment, fans and other power equipment.

ITECH's IT7900P full four-quadrant grid simulator provides two functional modes of AM and amplifier. In the working mode of the power amplifier, the grid simulator can amplify the external signal, and Delay  $\leq 65\mu s$ .

## Micro-grid test

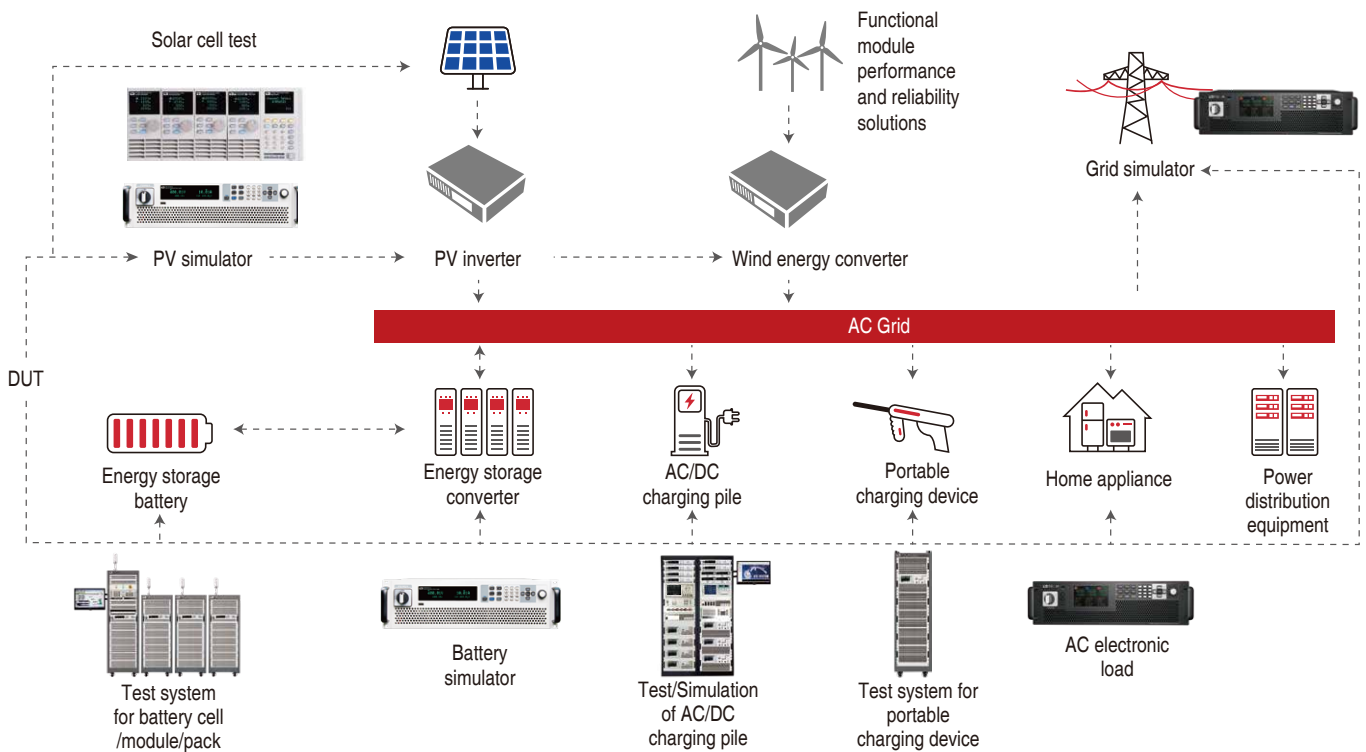

This information is subject to change without notice. For more information, please contact ITECH.

## ITECH ELECTRONIC CO.,LTD.

### Taipei

Add: No.918, Zhongzheng Rd., Zhonghe Dist., New Taipei City 235, Taiwan

Web: [www.itechate.com](http://www.itechate.com)

TEL: +886-3-6684333

E-mail: [info@itechate.com](mailto:info@itechate.com)

### Factory I

Add: No.108, XiShangqiao Nanlu, Nanjing city, 210039, China

TEL: +86-25-52415098

Web: [www.itechate.com](http://www.itechate.com)

### Factory II

Add: No.150, Yaonanlu, Meishan Cun, Nanjing city, 210039, China

TEL: +86-25-52415099

Web: [www.itechate.com](http://www.itechate.com)



ITECH Web



ITECH Facebook



ITECH LinkedIn

Thurlby Thandar Instrument Distribution  
Glebe Road, Huntingdon, PE29 7DR, UK

+44 (0)1480 412 451

[sales@ttid.co.uk](mailto:sales@ttid.co.uk)

[www.ttid.co.uk](http://www.ttid.co.uk)

**TT** *id* .co.uk

THURLBY THANDAR  
instrument distribution