

New Energy Vehicle Test Solution



Your Power Testing Solution

Index/About ITECH

About ITECH

As a professional global electronic instrument manufacturer, "Customer oriented" is the principle of all ITECH's activities. We do our best to acquire potential power test requirements of various industries. With continuously improvement and innovation, ITECH has the widest product line and best automatic electronic test solutions, promoting worldwide users' test experience to a new height.

Main products and solutions

More than 200 models of products: Programmable single and multi-channel electronic loads, high stability AC power supplies, programmable single and multi-channel power supplies, power meters and battery internal resistance testers etc.

Automatic testing system: Power Supply Automatic Test System, Battery Test System, Junction Box Auto Test Systems and Aging test systems etc.



Test Solutions

- Power Supply Test Solution
- Automotive Electronics Test Solution
- New Energy Test Solution

Test System

- Power Supply Test System
- Battery Test System
- Solar Cell Test System
- Automotive Junction Box Test System
- Charging Station/ On-board Charger Test Solution

Test Instrument

- AC/DC Power Supply
- AC/DC Electronic Load
- Bipolar DC Power Supply
- Power Meter
- Battery Internal Resistance Tester

Your Power Testing Solution

Automotive electronic devices test



Automotive electronic devices test

ITECH provides professional solutions to automotive electronic devices, e.g. car audio and GPS.

Our IT6500 series power supply built-in DIN40839 and ISO16750-2 waveforms, which simulate various disturbance situations of a car.

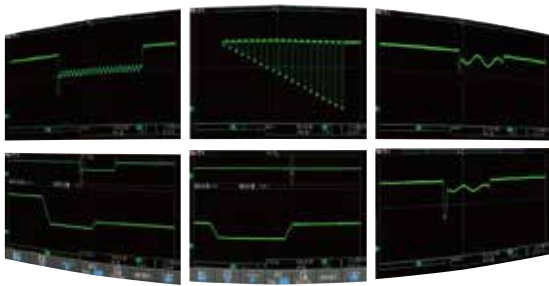

IT6500C Series
Wide Range High
Power DC Power
Supplies

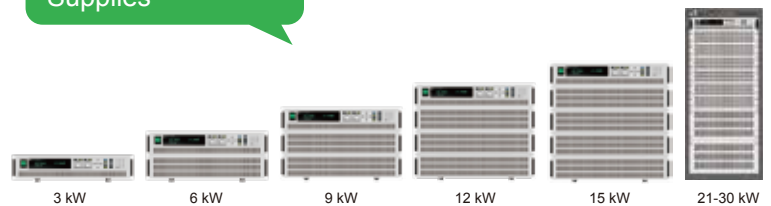

Products Recommended

IT6500 DC Power Supply, IT6900 DC Power Supply, IT6400 Bipolar DC Power Supply, Junction Box Test System.

Power turn-on /turn-off transient simulation

IT6500 series can simulate the disturbance during and after cranking. User can recall the standard waveforms (DIN40839 and ISO16750-2) directly from menu.

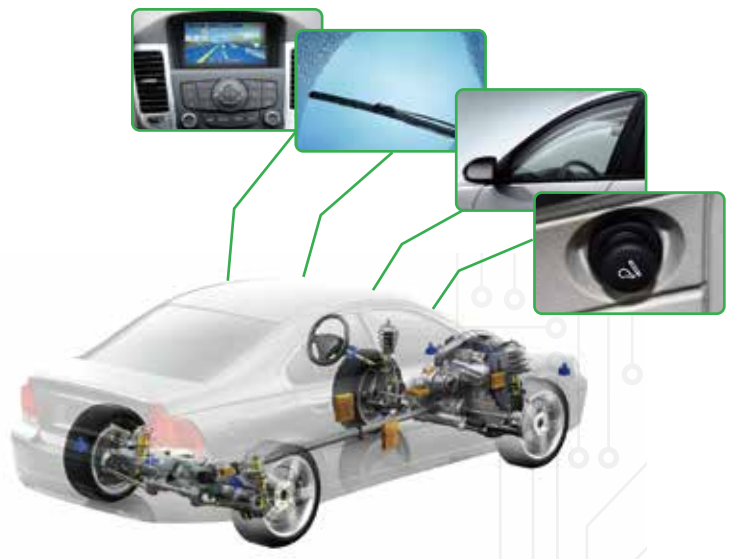
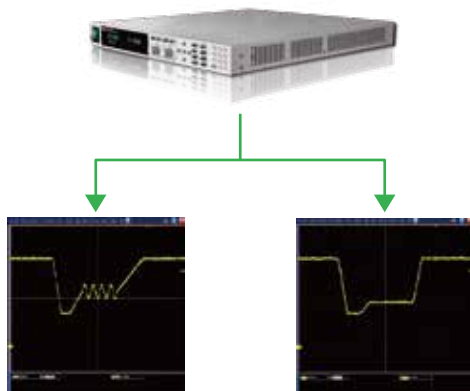

Your Power Testing Solution

Automotive electronic devices test

Reset performance (reboot) test

Many on-board devices have reset capability, such as the built-in micro-controller is used to ensure electrical reset function. The reset function performance test requires the voltage each time dropped 5% and keeps for a while, then dropped 5%... Cycle repeats. Standard specifies the DUT function status should reach ISO16750-1 defined C grade. IT6500 DC power supply provides the test curve, and can be recalled directly. Very convenient design.

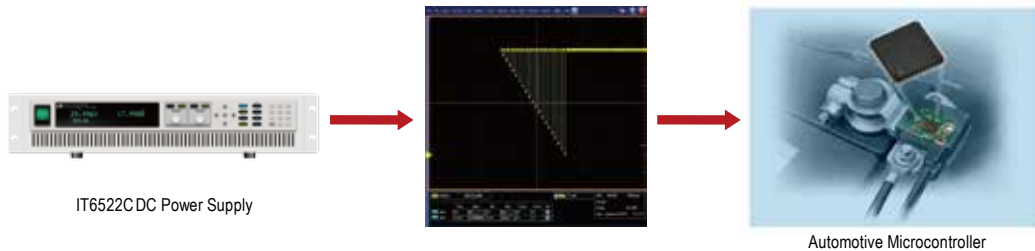

Voltage transients (Fuse blown) test

To prevent short circuit happening, each automobile electronic device has a fuse. Fuse test requires ISO16750-2 short circuit voltage drop curve and high speed programmable power supply. IT6500 DC power supply has fast voltage rising/falling rate (the fastest up to 1ms), that fully can meet the test requirements.

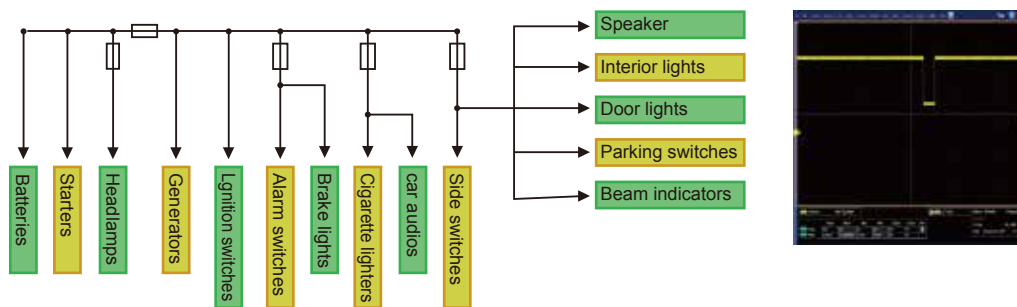

Junction box test

ITECH provides professional and reliable test system for auto junction box test.

- Accessories test
- Fuse test
- Stability of long term working
- Temperature monitor and fault alarm
- Relay life test
- Others



Products Recommended

Junction box test system



New Energy Test Solutions

Charging Station Test

Today, the clean-energy automobile technology is developing in full swing, therefore, to guarantee the quality of the battery charging or discharging products used in this field, an excellent testing solution must be introduced. ITECH offers all kinds of different testing solutions like AC power supply, DC power supply, electronic load rating from hundreds watts to hundreds Kilo-Watts and they all perfectly satisfy various electrical automobile testing requirements. On top of that, ITECH also provides built-in testing plan based on ISO16750 and DIN40839 standards in order to make ITECH testing solutions specializing in automotive electronics be more reliable and multi-functional.

ITECH Test Solution Advantages

- Module design, customized auto test system
- High power electronic load can reach up to 600 kW, meet test requirement of high power DC charging pile
- Built in standard test items
- Compatible with multiple protocols for charging piles, ideal for testing various charging piles
- Fill-in-blank user interface, no need of programming ability
- Customized test report

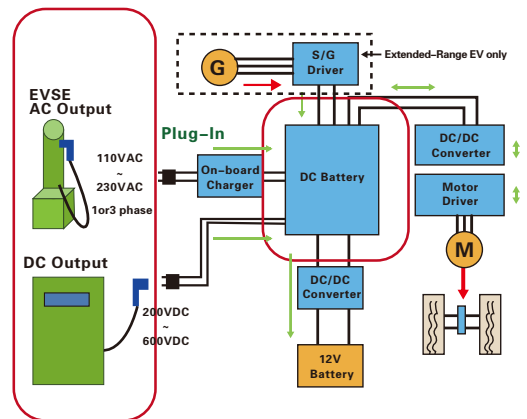

Products Recommended

AC Power Supply >>>

IT7600 Series

IT7300 Series

- Output range:
0~500 V/0~72 A/0~18 kVA
- Adjustable phase angle: 0~360°
- Input power interference simulation

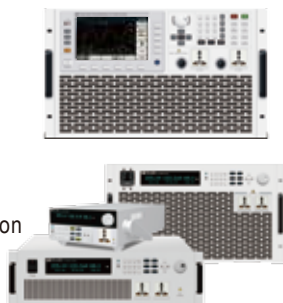

DC Power Supply >>>

IT6700H Series

- Input range (standalone):
0~1200 V/0~110 A/0~3000 W



IT6500

- Input range (standalone):
0~30kW
- 2-quadrant current seamless switching



AC Electronic Load >>>

IT8615

- Input range (standalone):
0~420 V/0~20 A/0~1800 W
- Measurement:
V,I,PF,CF,P,Q,S,F,R,Ip+/-,THDv
- Parallel/ 3-phase control



DC Electronic Load >>>

IT8800 Series

- Input range: 0~600 kW
- 4 operation modes: CC/CV/CR/CP

IT8700 Series

- Removable modules for easy system configurability
- Support 16 channels simultaneously test with mainframe extension



Your Power Testing Solution

New Energy Test Solution

AC Charging Station Test

System Structure

AC charging pile outputs AC and is converted to DC by on-board charger to charge the electric vehicle battery.

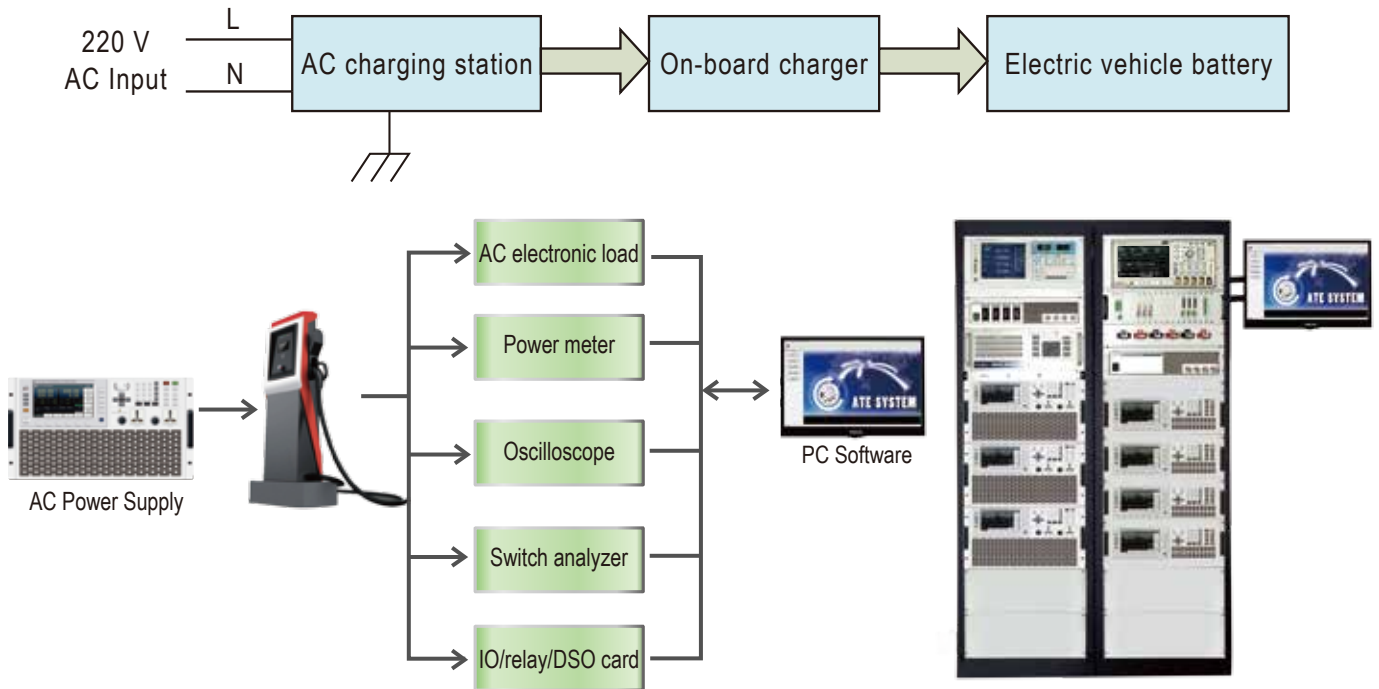

Testing Items

	No.	Testing Items	No.	Testing Items
	AC Charging Station	1	Test before power-on	8
2		Power-on test	9	Over current protection test
3		Electric vehicle (EV) conductive test	10	Leakage current protection test
4		Connection status test with load	11	Input over voltage protection test
5		Input/Output performance test	12	Input under voltage protection test
6		Measured data compliance test	13	Unnormal connection test
7		Display function test	14	Emergent stop function test

Products Recommended

Instrument	Function Required	Specification	Model
AC Power Supply	City electricity simulation capabilities	500 V/36 A/9 kVA	IT7600 Series
AC Electronic Load	1. High power 2. 47-63 Hz	50-420 V/0-20 A/1800 W Parallable for power extension	IT8615

DC Charging Station Test

System Structure

As a fast charging product, DC Charging station has higher output power and voltage thus only high power and high voltage DC electronic load can satisfy its testing demand.

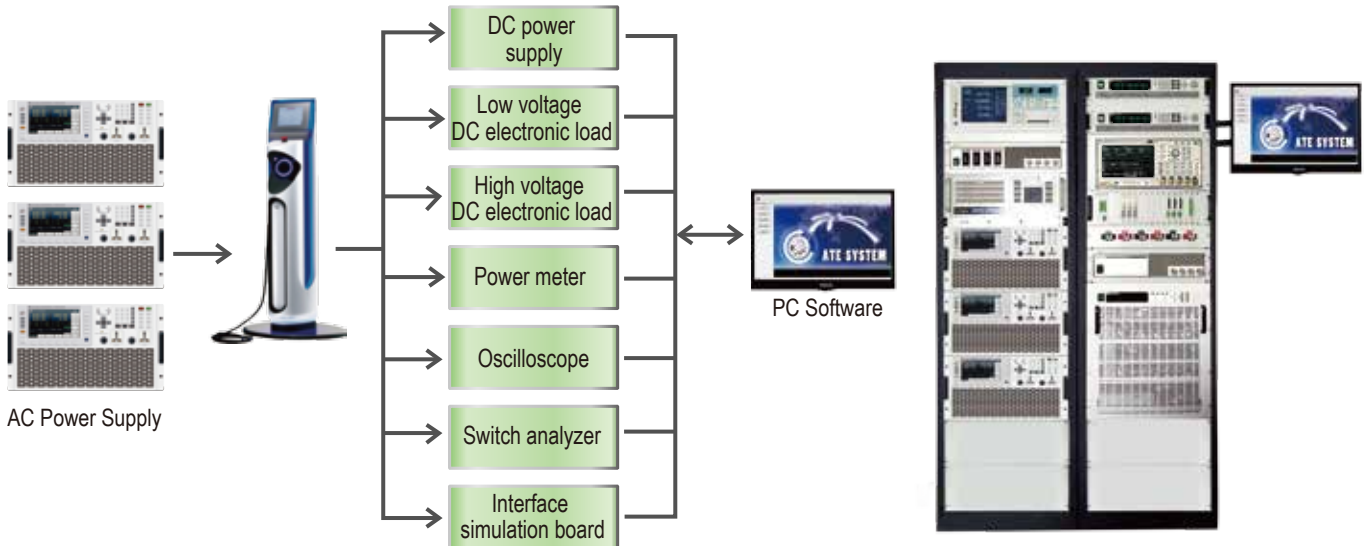

Testing Items

	No.	Testing items	No.	Testing items
	DC Charging Station	1	Output voltage deviation test	12
2		Output current deviation test	13	Input under voltage protection test
3		Voltage & current regulated accuracy test	14	Output over voltage protection test
4		Ripple and noise test	15	Output short circuit protection test
5		Efficiency test	16	Inrush current test
6		Power factor test	17	Battery reverse connection test
7		Current unequally assigning ratio test	18	Unnormal connection test
8		Voltage & current limit test	19	Emergency stop function test
9		Display function test	20	Soft-start test
10		Input function test	21	Discharge test
11		Communications test		



Products Recommended

Instrument	Function Required	Specification	Model
AC Power Supply	1. 3-phase parallable control 2. Electricity supply simulation capability	≥80 kW	IT7600 Series/Customized
DC Electronic Load	1. High accuracy 2. Fast response	120 V/240 A/3000 W	IT8816
	DC charging station's power: 80 kW/100 kW/120 kW	80 kW/100 kW/120 kW	IT8800/IT8900 Series

Your Power Testing Solution

New Energy Test Solution

On-board Charger/ Charging Interface Test

EV battery Charger can be classified into on-board charger and external charger. ITECH on-board charger test system includes electronic load for discharging battery, AC source for simulating grid supply, oscilloscope, power meter and professional software to guarantee the complete test for charger.

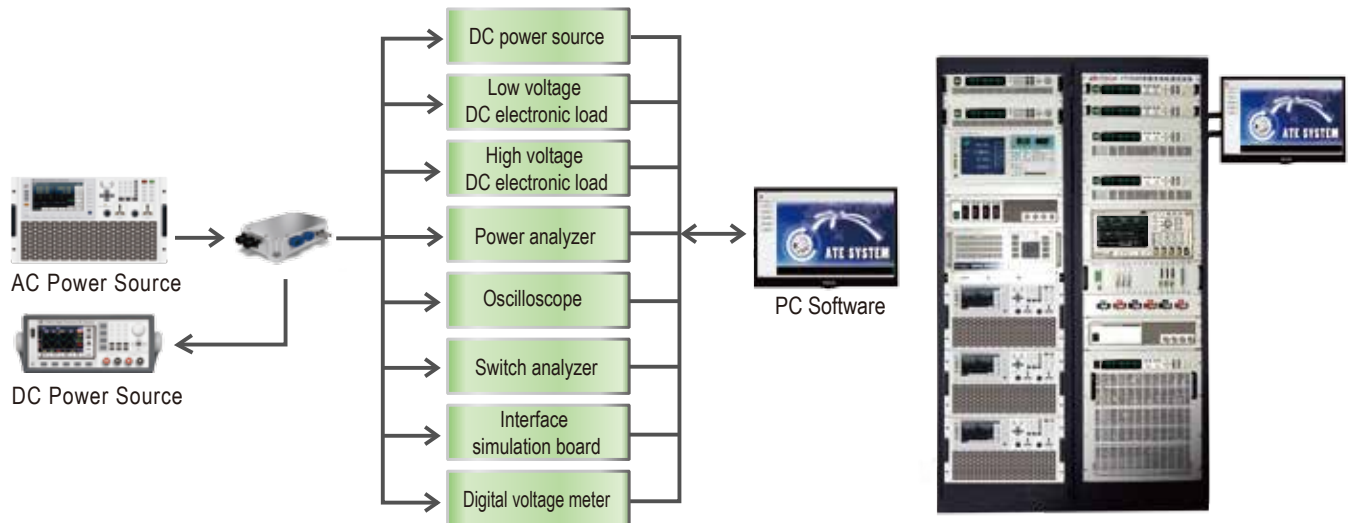

Test Items		
Input	Input & Output Test	Efficiency Test Power Factor Test Power Test Voltage & Current Test
	Static Test	Ripple and Noise Test Output Voltage & Current Test
	Line Regulation Test	Input Voltage Deviation Test Input Current Deviation Test
	AC Cycle Dropout Test	AC Cycle Dropout Test
	Power Line Disturbance Test	Power Line Disturbance Test
	Input Voltage Frequency Range Test	Input Voltage Frequency Range Test
Output	Load Regulation Test	Output Voltage Deviation Test Output Current Deviation Test
	Output Voltage Range Test	Output Voltage Range Test
	Voltage Limit Test	Voltage Limit Test
	Current Limit Test	Current Limit Test
	Output Regulated Accuracy Test	Voltage Regulated Accuracy Test Current Regulated Accuracy Test
Protection	Input Voltage Protection Test	Input UVP Test Input OVP Test
	Output Voltage Protection Test	Output UVP Test Output OVP Test
	Short Circuit Protection Test	Short Circuit Protection Test
	Communication Interrupt Test	Communication Interrupt Test
	Reversed Connection Protection Test	Reversed Connection Protection Test
Time Series Tests	Parameter Configuration Error Protection Test	Parameter Configuration Error Protection Test
	Turn On Test	Inrush Current Test Voltage Overshoot Test Steady State Current Test Turn On Time Test, Rise Time Test
Special Tests	Turn Off Test	Turn Off Time Test, Fall Time Test
	Reliability Test (Life Cycle Test)	Reliability Test (Life Cycle Test)

Test items: CC test, CP test, PWM simulation test, normal power off test, abnormal power off test.

On-board Charger & Coupler Connection Test

Test System Advantages

Self control charger, easy operation

Vehicle Control Unit (VCU), Motor Control Unit (MCU) Battery Management System (BMS) are the most important technology that will affect Vehicle's dynamic performance, cost, reliability and safety. Test System can communicate with BMS and limit charger's charging voltage, current and power. It has complete test items that can test EV charger automatically and intelligently.

Compatible with protocols of all kinds of car charger, Applicable to test all types of car charger

Car Charger and BMS use CAN bus communication, DBC file is the protocol file of CAN to collect data and analyse. It includes sending and receiving data packets and packet ID. ITS9500 test system software support importing and translating. DBC file, which is suitable for all kinds of EV charger.

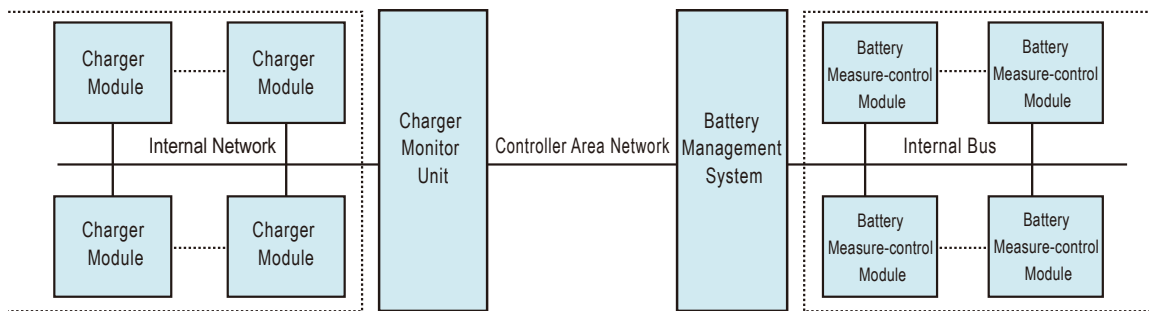

Charger Monitor Unit And BMS Network Topology

Testing Software

ITECH testing software has friendly user interface, only need user to check and fill in the blanks of test items, without requesting for programming ability, making operation more simple and easy.

ITECH testing software provides customized report which can be edited and export as factory test report.

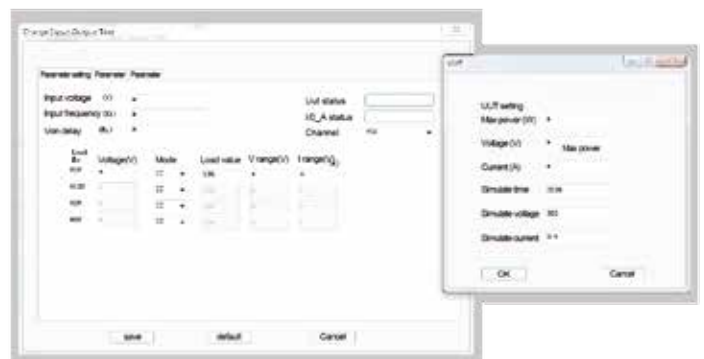

Your Power Testing Solution

New Energy Test Solution

Electric Vehicle Battery Test

Battery Internal Resistance Test

Generally, battery pack is composed of several battery cell connected in series. ITECH integrated power battery test solution including battery internal resistance test, battery pack reliable test and discharge performance test, battery module performance and function test, vehicle simulation test.

Measurement of DC Internal Resistance

For high-capacity batteries applications, such as power batteries, it is inconvenient or impossible to test the ACIR. So generally battery pack is assessed by its DCIR. DCIR testing includes resistances of electrolyte, battery lead plate, and polarization reaction.

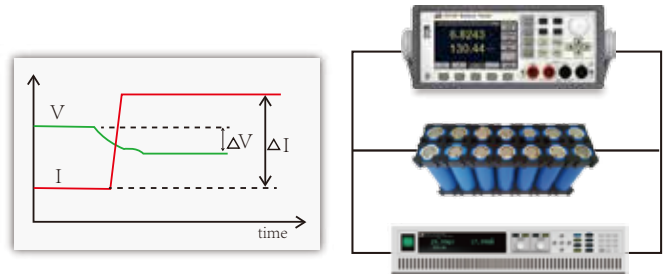

Measurement of AC Internal Resistance

A battery pack is typically multiple battery cells in serial connection. A sharp difference between the cells may greatly damage the battery pack's capacity and discharge performance. Therefore, measurement and systematic analyse of cell IR is an important part of battery performance test and it is a must test item for power battery. The battery IR is not a constant value and it keeps changing while charging and discharging. The dynamic IR and voltage of each cell can be tested simultaneously by on-line IR tester IT5102, so as to monitor whether any battery has failed.

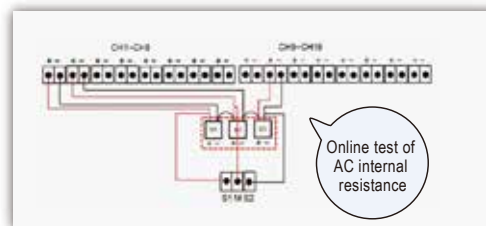
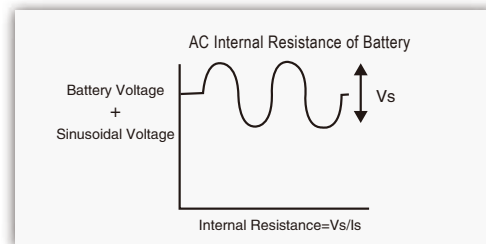

Tips

AC IR internal resistance conforms to IEC standards:

- The frequency of test signal is 1 KHz±0.1 KHz, sine wave.
- The voltage drop of battery's two terminals caused by AC signal should be within 20 mV
- Ambient temperature: 20 C ± 5 C

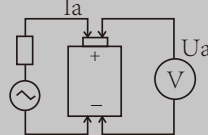

Products Recommended

Instrument	Function Required	Specification	Model
Battery Internal Resistance Tester	<ol style="list-style-type: none"> 1. Battery AC/DC internal resistance test 2. Multiple test range for option, high precision and high resolution 3. Built-in multiple communication interfaces 	-300~+300 V 3 mΩ-3 Ω	IT5101 IT5101E

Dynamic Simulation Test

Electric Vehicle Battery Test – Braking Current Regenerative Simulation

When electric vehicle brakes, to reach the same effect of petrol cars braking, the output I/V curve of EV battery should follow a deceleration curve standard. For practical EV battery test, the simulation of bidirectional braking current is necessary, and the test time should be within 10ms. So the reliability of the test depends on the response speed of test instrument.

1- Traditional solution: Adopt two separate units, such as a DC Power Supply with an Electronic Load, which has a lot of drawbacks, such as complicated system construction, incontinuous voltage waveform and often cannot reach the testing requirement for speed;

2- ITECH solution: IT6500C provides fast and seamless switching between sourcing current and sinking current, with support of power dissipater unit, IT6500C can extend sinking current and power. It is an ideal solution for bidirectional and regenerative energy system test, such as braking current, battery system, etc.

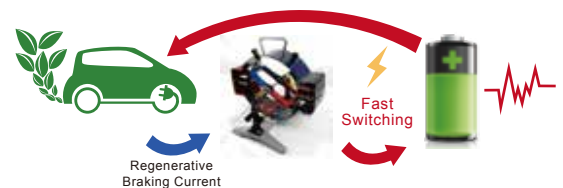
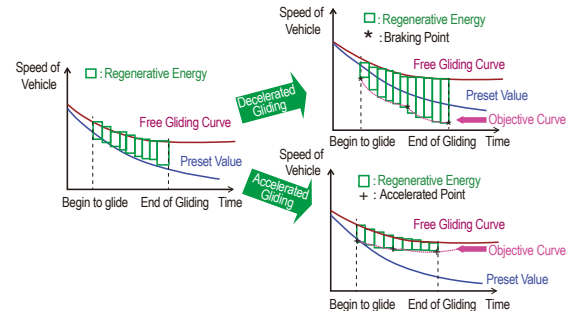

>> IT6500C Series Wide Range High Power DC Power Supplies

Dynamic Discharging Test

When an electric vehicle is moving, its battery discharging waveform is dynamic changing, the dynamic discharging test can simulate the discharging status of the electric vehicle battery and calculate the remaining mileage.

IT8700 and IT8800 series electronic load have 25 kHz dynamic mode. Adjustable current rising/ falling speed in List mode supports user defined current changing, which is suitable to simulate EV battery working status. Moreover, IT8800 series can control the load current via external analog interface with fast response time, which complement the List function.

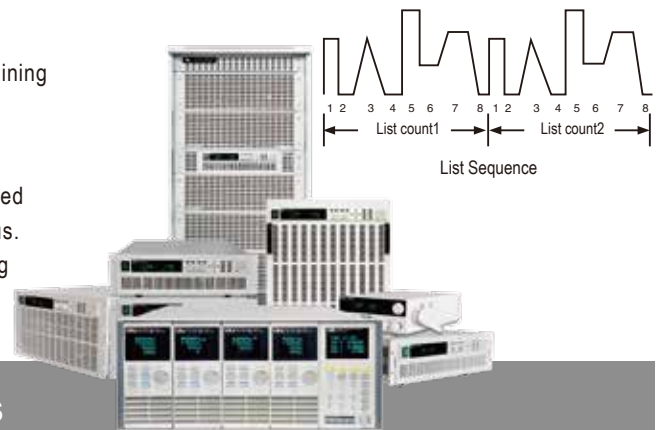

>> IT8700 / IT8800/ IT8900 Series Electronic Loads

👍 Products Recommended

Instrument	Function Required	Specification	Model
DC Power Supply	1. Current source/ sink 2. Seamless switching between sourcing and sinking current 3. Fast voltage and current changing	800 W-30 kW	IT6500C Series
DC Electronic Load	1. Programmable current changing waveform 2. High speed voltage and current measurement, high speed dynamic mode.	Multi-channel test	IT8700 Series
		Single channel test	IT8800 Series (Available for analog control)

Your Power Testing Solution

New Energy Test Solution

Reliable and discharging performance test of battery pack

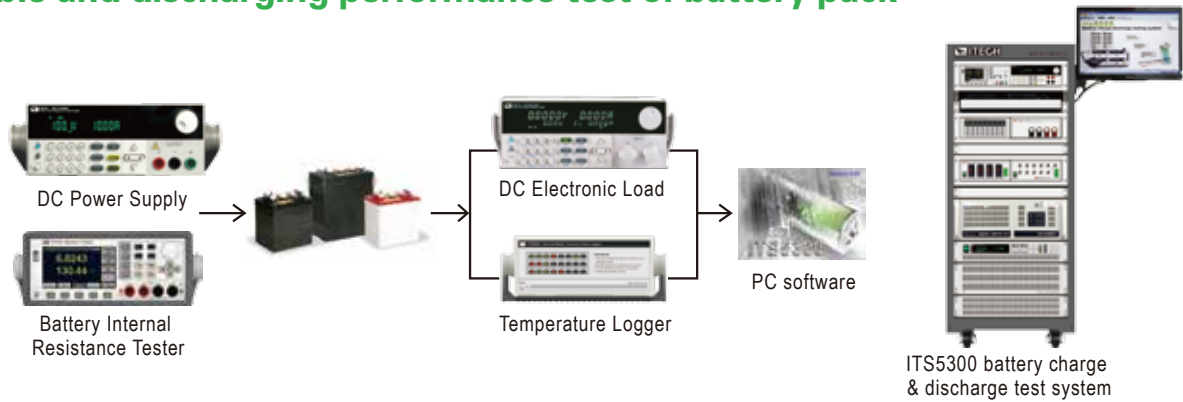

Test Items—Battery cell and battery pack

- Internal resistance test: online/offline AC/DC IR test.
- Charge and discharge performance test, curve depicted automatically.
- Temperature test
- Life cycle test
- Capacity test

ITS5300 Test Software

ITECH test software has ultrafast response and 50 kHz I/V sampling rate. One set of software can test hundreds of battery pack simultaneously. ITS5300 software has a lot of functions, e.g. power-off memory protection, complete charge & discharge protection, data backup, configuration of user access rights, various step editing, optimized report and analysis functions, data Excel export, easy programming etc.

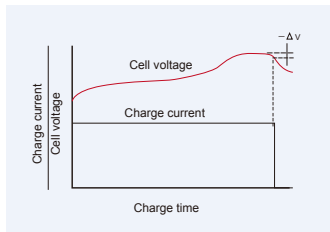

Temperature test

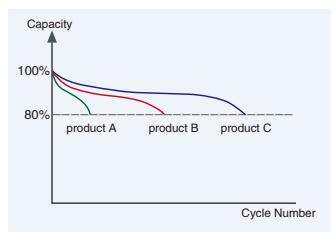

Life cycle test

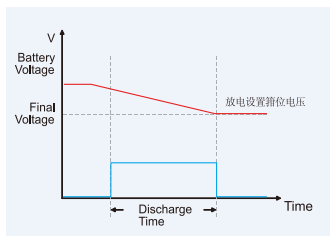

Charge and discharge performance test

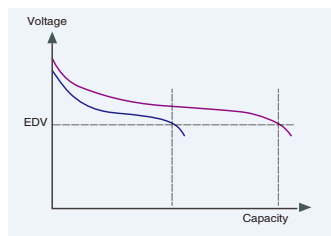

Capacity test

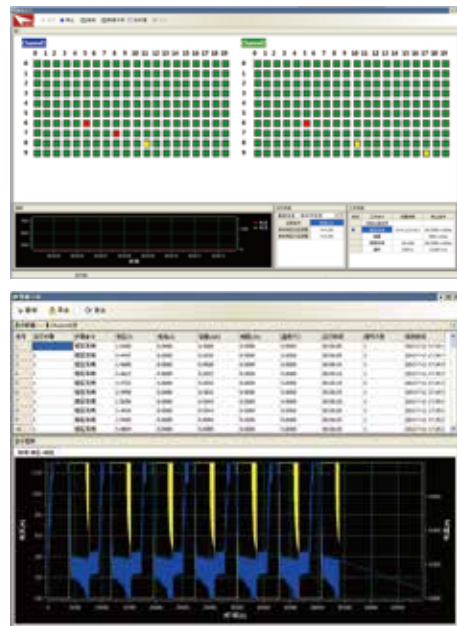

Seamless switching between 2-quadrants/ Charge & Discharge test

Work with IT-E500 power dissipater unit, IT6500C greatly expands the sinking current and power, which can be widely applied in bidirectional current test or battery system charging/discharging test. Each IT-E500 series power dissipater unit can sink up to 3 kW. By paralleling multiple power dissipater units, the sinking power can reach up to 300% (Max.90 kW) of source power, which can meet the requirement of high power test.



Portable Lithium Battery Test



Cellphones



Wearable electronics



Unmanned Aerial Vehicles (UAV)



Portable Speakers

Charge-Discharge Cycle Test

Lithium battery will be charged with constant current initially. After detecting battery has reached 80% state of charge, power supply will change to CV mode to charge. Make sure the accuracy of stop voltage is within 1%. The discharge test is executed under different temperature, and the battery capacity will be recorded.

ITECH IT6412 dual channel bipolar DC power supply can excute charge and discharge at the same time. The voltage, current and charged/ discharged capacity of battery can be observed and the charge/ discharge curve will be displayed on screen.



Lithium Battery Protection Test

The changes and response time under over-charge, over-discharge and short conditions will be measured. The instant time of over protection and short response time normally are hundredth μ s level. The request to DC supply response speed is very strict.

ITECH IT6412 dual channel bipolar DC power supply is with ultrafast dynamic response. The response time is less than 50 μ s when 50%~100% load recover to 50 mV.

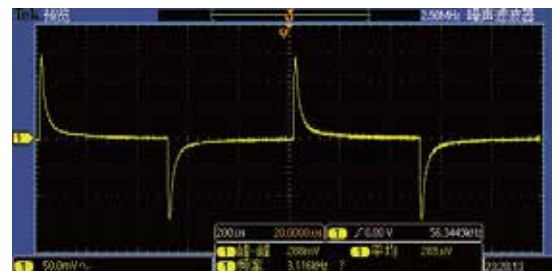

IT6412 transient response curve

Lithium Protection Panel Test

The protection panel is to guarantee the steady charge/ discharge of lithium battery pack in serial connection, prolong the lifespan of battery. ITECH IT6412 dual channel bipolar DC power supply has the function of battery simulation that the output resistance can be set from 0-1 Ω , and .csv file can be imported to simulate a user-defined battery. Ultrafast dynamic response time with fast A/D sampling rate, ensures accurate test of protection time. The readback current resolution is up to 100 nA, capable of measuring micro current.

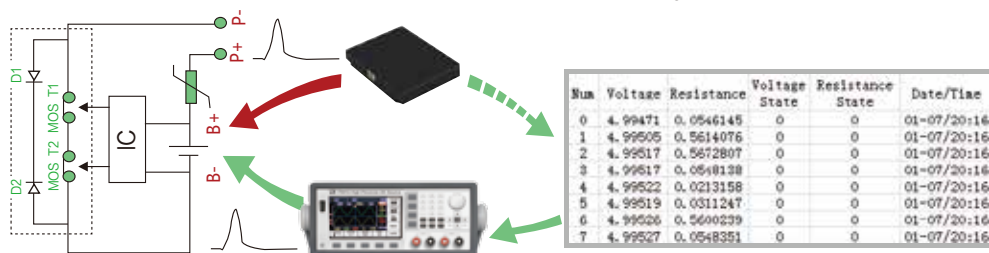

Products Recommended

Instrument	Function Required	Specification	Model
Bipolar DC Power Supply /Battery Simulator	1. Output positive & negative voltage and current 2. Fast dynamic response 3. Editable output resistance	± 15 V/ ± 3 A/45 W	IT6412
		other specifications	IT6400 Series

Your Power Testing Solution

New Energy Test Solution

LED Test

LED Power Driver Test

System Structure

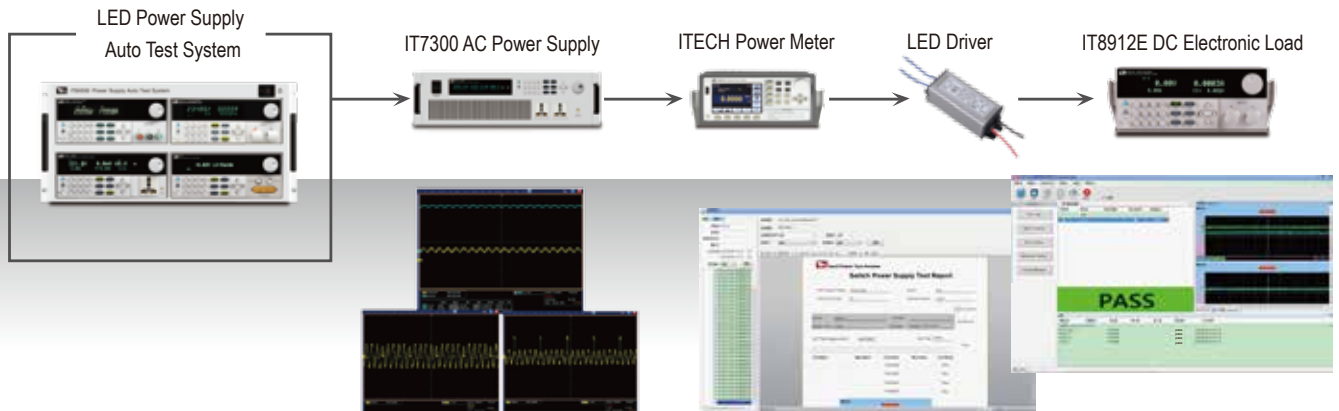

Simulate Power Line Disturbance Waveform

Testing Items

Input Test	Output Test	Protection Test	Time Series/Dynamic Test	Stability Test	Special Test
<ol style="list-style-type: none"> Input Disturbance Test Input Power-off Test Input Inrush Current test Input RMS Current Test Input Peak Current Test Input Power Factor test Input Voltage Rising/Falling Test Input Frequency Rising/Falling Test 	<ol style="list-style-type: none"> DC Output Voltage Test DC Output Current Test Peak To Peak Noise Test RMS Noise Test Current Ripple Test Efficiency test In-test Adjustment Test Power Good Signal Power Fail Signal Power Supply On signal Voltage Overshoot Test 	<ol style="list-style-type: none"> Over voltage Protection Test Over Load Protection Test Over Power Protection Test Short-circuit Protection Test Under Voltage Protection 	<ol style="list-style-type: none"> Turn On Time Test Turn Off Time Test Rising speed Falling speed Transient Spike Test Attachment Point Timing Test Output Voltage Sequence 	<ol style="list-style-type: none"> Power Effect Test Load Effect Test Mixed Effect Test 	<ol style="list-style-type: none"> Extended Measurement point Test Analog Output Control PWM Output Control CAN Bus Read/Write GPIO Read/Write RS232 Read/Write RS485 Read/Write I2C Read/Write TTL Signal Control Relay Control Bar Codes Scan Quick Charger 2.0 Test



Products Recommended

Instrument	Function Required	Specification	Model
AC Power Supply	<ol style="list-style-type: none"> Simulate electric grid disturbance Surge/trapped wave simulation AC source distortion simulation Adjustable phase angle 	300 VA	IT7321
		1500 VA	IT7624
Power Meter	<ol style="list-style-type: none"> Measure Vrms/Vpk/Irms/W/Va/Var/PF/CF/Frequency/THD/Energy Harmonic spectrum of voltage and current waveform analysis 	600 Vrms/20 Arms 100 KHz 0.1% Voltage & Current accuracy	IT9121
DC Electronic Load	<ol style="list-style-type: none"> CR-LED mode, LED V-I characteristic simulation Adjustable frequency and PWM output Pulsating current and inrush current test 	500 V 300 W	IT8912E

LED Lighting Test

Limit inrush current and protect LED

When power on general power supply, it will generate inrush current. With test current increase, inrush current will also increase which may reduce LED lifespan. ITECH DC power supply can effectively limit inrush current, protect LED.

Startup of general power supply

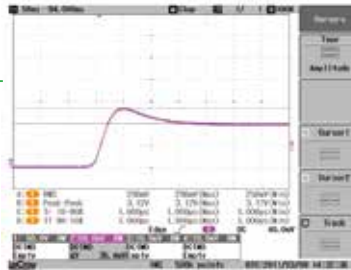

With obvious inrush current

startup of IT6874A

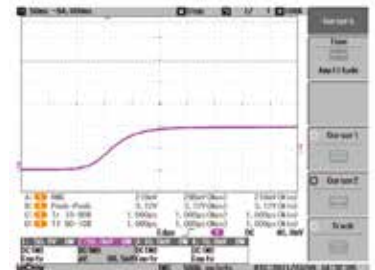

No inrush current

With starting micro-current, voltage rise more rapidly, improving LED test efficiency

When output micro-current, general power supply may easily enter limiting current mode which will lead to slow voltage rise and take more time to light LED. With higher voltage and smaller current, the rising time will be prolonged.

ITECH IT6200 dual-range DC power supply has low current mode, which can light LED very fast.

Startup of general power supply

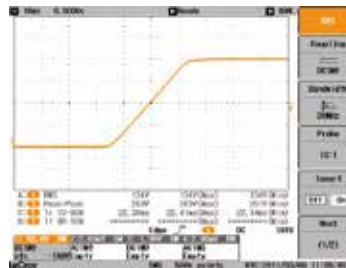

Voltage rise slowly

Startup of IT6235

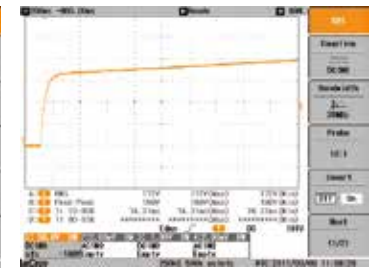

Voltage rise rapidly

Forward and reverse leakage current test

LED leakage is extremely small, it reached the level μA . Normally the current can not be captured. Readback resolution of IT6412 Bipolar DC Power Supply can reach μA level and meet test leakage current test requirements.



Products Recommended

DC Power Supply	1. Power-on without overshoot 2. Micro current power-on, voltage rising fast 3. Positive and negative μA level current leaking test	$\pm 15 \text{ V}/\pm 3 \text{ A}$	IT6412
	1. Power-on without overshoot 2. Dual range output	150 V/2 A	IT6874A
	Turn-on without overshoot	150 V/10 A	IT6953A

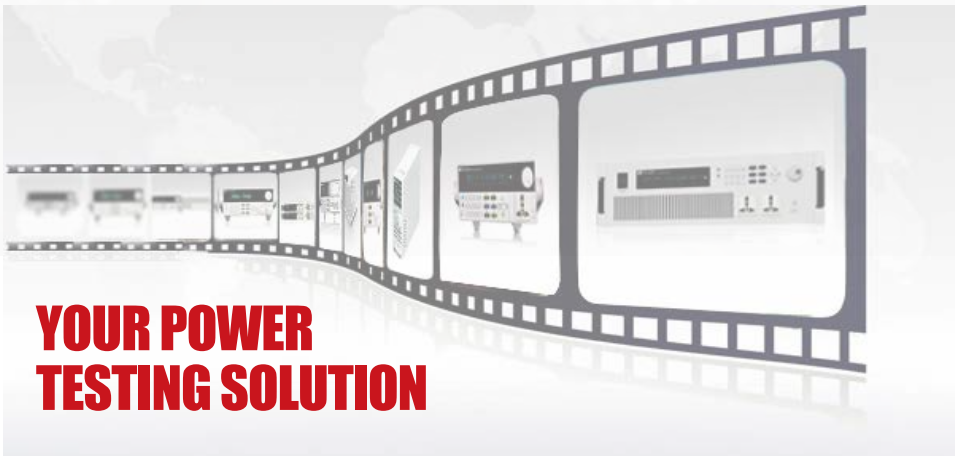
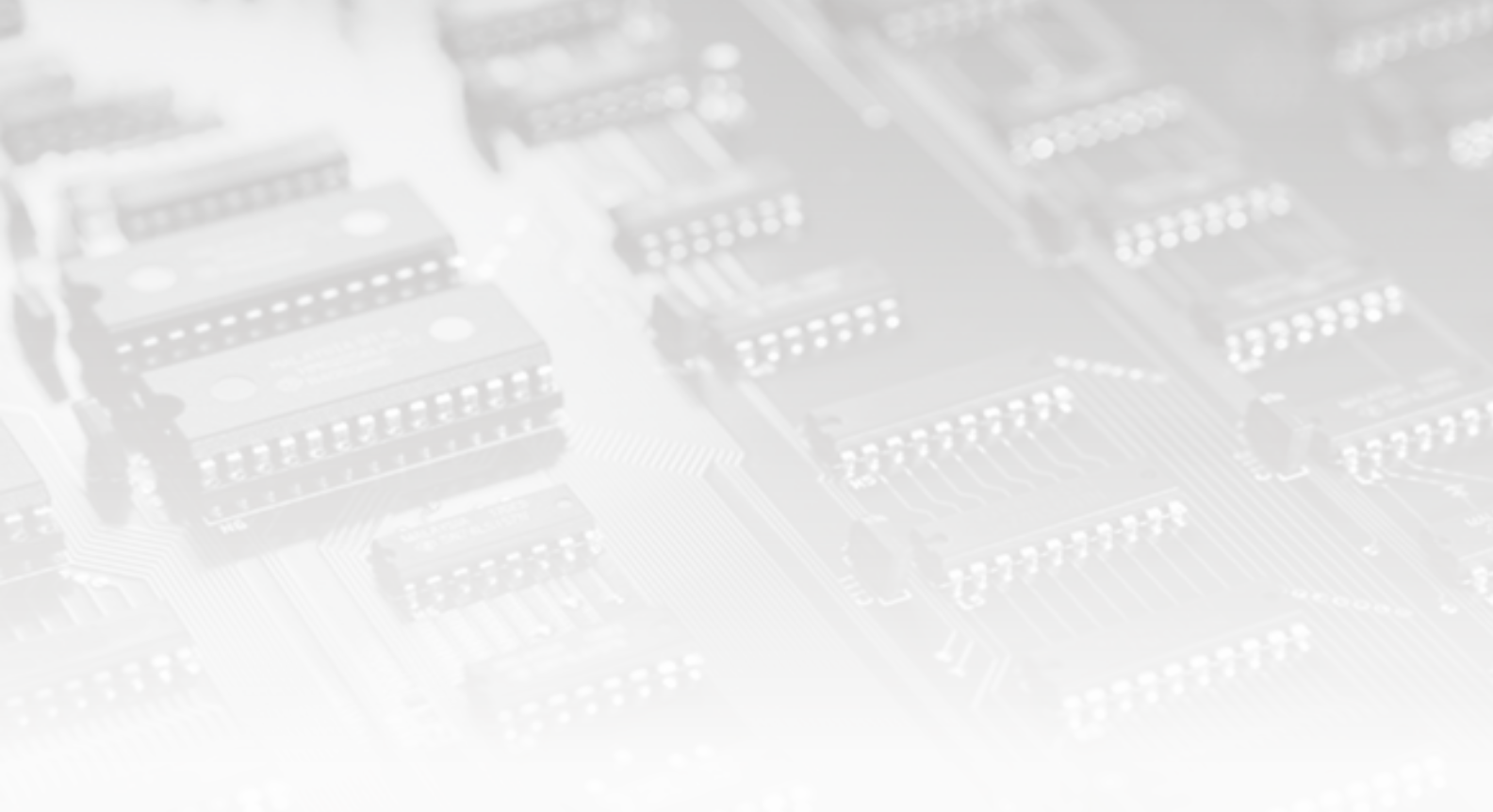

This information is subject to change without notice. For more information, please contact ITECH.

Taipei

Add: No.918, Zhongzheng Rd., Zhonghe Dist., New Taipei City
235, Taiwan

Web: www.itechate.com.tw

TEL: +886-3-6684333

E-mail: taiwan@itechate.com.tw

Xishan Factory

Add: No.108, XiShanqiao Nanlu, Nanjing city, 210039, China

TEL: +86-25-52415098

Web: www.itechate.com

Meishan Factory

Add: No.150, Yaonanlu, Meishan Cun, Nanjing city, 210039, China

TEL: +86-25-52415099

Web: www.itechate.com

Thurlby Thandar Instrument Distribution
Glebe Road, Huntingdon, PE29 7DR, UK
+44 (0)1480 412 451
sales@ttid.co.uk
www.ttid.co.uk

